

Cultural values among managers and subordinates: A Comparative study of Hofstede's cultural dimensions between public and private sectors in Saudi Arabia.

Dr Suzan AlQurashi

*Assistant Professor of Organisational Behaviour and Public Administration
Public Administration Department, Faculty of Economic and Administration
King Abdulaziz University, Jeddah, Saudi Arabia.
salqurashi@kau.edu.sa*

(researchdeliverydate28/7/1433H ◀ researchacceptancedate03/3/1434H)

Keywords. cultural dimension, individualism/collectivism, uncertainty avoidance, power distance, masculinity/femininity, public sector, private sector.

Abstract. Hofstede's work-related cultural dimensions have been used as a research model in the field of management. His classification of countries according to the four work-related cultural values of power distance, uncertainty avoidance, masculinity-femininity, and individualism-collectivism has influenced many studies of cultural values. Hofstede has proposed several areas for continued research, such as non-Anglo cultural dimensions. In accordance with Hofstede's proposal, the current study examines differences of the work cultures between public sector and private sector organisations in Saudi Arabia, using a sample of 320 employees from different organisation levels (drawn from four Saudi ministries and two private companies). Confirmatory factor analyses (CFA) support the multi-dimensionality of the cultural dimensions. The findings reveal the level of each dimension in both sectors. In particular, the findings highlight significant differences between the groups in two of the dimensions, uncertainty avoidance and power distance. The findings also permit an exploration of a number of issues pertaining to cultural dimensions that impact the behaviour of employees. One noteworthy example is the high degree of uncertainty avoidance observed among Saudi top-level public-sector managers. The results reveal that there are significant differences between the PD level in public and private sectors, with the unexpected result that PD in the private sector is significantly higher than in the public sector. These results have important implications for the nature of decision-making and management among government and private employees, both for Saudi Arabia and for the Gulf Cooperation Council countries as a whole. An important finding is the strong support for Hofstede's cultural dimensions, not only in distinguishing environments across nations, but also within a homogenous work-setting within one country.

Introduction

Every society has its own values, attitudes, thinking, beliefs and behaviours. The individuals of a society share common goals and meanings that differentiate them from others; this differentiation is called 'culture'.

Geert Hofstede (1980) examined cultural and workplace differences. He carried out a large-scale study of IBM employees from over 50 nations. By identifying the collective trends that affected the behaviour of the employees, Hofstede initially identified four main collective constructs that differ between cultures and labelled them as the following cultural dimensions: masculinity versus femininity (M/F), uncertainty avoidance (UA), individualism versus collectivism (I/C) and power distance (PD).

These dimensions have been used by many researchers to account for observed distinctions in individual behaviours across cultures and countries (Geladeet al., 2008). According to the Social Science Citation Index, Hofstede (1980; 2001) was cited nearly 2858 times from 1987 to 2004, placing his research among the most cited works (Bearden et al., 2006). Hofstede's work continues to be relevant and remains the most popular measure of cultural values, offering a theoretical framework for guiding cross-cultural comparisons of organisational commitment (Randall, 1993; Clugston et al., 2000; Kirkman and Shapiro, 2001).

Hofstede's index identifies four cultural dimensions and assigns each country an aggregate score. Therefore, it is possible to use judicious comparisons to differentiate between the cultural orientations within the data under consideration. However, there are major issues pertaining to the use of Hofstede's index. First, researchers often rely on Hofstede's (1980) results without considering the cultural changes that may have occurred during the past 30 years (McCoy, Everard, and Jones, 2005). Second, Hofstede designed his index in such a way that the country scores would ideally fall between 0 and 100. However, it is not uncommon for some countries to score higher than 100.

Hofstede's Cultural Dimensions

Most research into cultural dimensions has been conducted in the West and has measured cultural dimensions by making comparisons between countries. The majority of cultural studies have focused on national analyses, comparing aggregated scales of cultural values across countries (Hofstede, 1980; Schwartz, 1999). Only a few studies have examined the impact of personal cultural values on attitudes and behaviours at the individual level. Furthermore, only a limited amount of research to date has explored cultural effects based on the sector of society (public and private).

Accordingly, this research has attempted to understand the cultural impacts on sectors (public and private) in a non-Western culture and to support cultural theory by testing for differences between public and private employees using Hofstede's cultural dimensions of (M/F), (UA), (I/C) and (PD). In this study, we employed the individualised measures of Clugston et al. (2000) because, when we consider culture within one country, it is important to understand the degree to which variation within that country persists through cultural dimensions and whether this variation is sufficient for hypothesis testing.

Even though prior studies have frequently used value scores to determine the characteristics of entire cultures, an increasing number of researchers have acknowledged that value orientations can also be used to reveal the characteristics of individuals. This type of psychological analysis is more responsive to the potential effects of cultural values on the behaviour of a single individual, relative to analyses that consider all of the members of a culture to be identical (Tyler, Lind, and Huo, 2000). Two particular causes have been advanced in support of the individual level of analysis, as reported by Cohen and Keren (2008). First, there are within-culture differences in terms of social norms. The treatment of individual reports on the nature of one's culture as group-level variables can lead to possible misspecification problems. Second, the implication that experimental distinctions can be

recognised by a clustering variable might be better explained by using a more fine-grained analysis conducted at the individual level (Cohen and Keren, 2008).

Masculinity versus femininity (M/F)

Hofstede's M/F dimension is related to the division of emotional roles between men and women. This dimension measures the degree to which social gender roles are distinguished and reflects a balance between male assertiveness and female nurturance. According to Hofstede (2001), masculine gender roles within a society are distinct; some of the major values include assertiveness, advancement and the acquisition of money and material possessions, whereas "Women in masculine societies are supposed to be more modest, tender, and concerned with the quality of life" (p. 297). In more feminine societies, "gender roles overlap, both men and women are supposed to be modest, tender, and concerned for quality of life" (p. 297).

The literature is inconclusive regarding how the M/F cultural dimension might affect the psychological links of employees to their organisation. Randall (1993) concluded that there were variations in the masculinity scores across countries; for example, Japan has the highest masculinity score and South Korea the lowest among the countries studied." Canada had a medium level of masculinity.

Uncertainty avoidance (UA)

UA describes intolerance for uncertainty or ambiguity and the need to reduce uncertainty. It indicates the extent to which a culture programmes its members to feel either uncomfortable or comfortable in unstructured situations (Hofstede and McCrae, 2004). In high UA cultures, individuals have little tolerance for uncertainty. Individuals with high levels of UA tend to look for more stability and formal roles and wish to avoid risk; hence, they enjoy longer tenures and exhibit lower levels of intention to leave their organisation. Therefore, organisations in these cultures use formal roles and regulation to reduce internal uncertainty (Hofstede, 2001).

Chew and Putti (1995) confirmed Hofstede's observation regarding a high UA score in a Japanese sample. Japanese conservatism is reflected in a high level of faithfulness to rules and a greater long-term commitment to organisations. The authors asserted that individuals who score high in UA are reluctant to deal with further uncertainty; they avoid risk because they fear both responsibility and failure.

Individualism versus collectivism (I/C)

A thorough analysis of the I/C dimension has revealed a theoretical link between this dimension and the psychological relationship between an individual and an organisation (Randall, 1993). Hofstede (2001) explained I/C in this way: "It describes the relationship between the individual and the collectivity that prevails in a given society. It is reflected in the way people live together (e.g., in nuclear families, extended families or tribes) and it has many implications for values and behaviour" (p. 209). Hofstede defined individualism (along with its polar opposite, collectivism) within the context of a national culture in the following way: "Individualism stands for a society in which the ties between individuals are loose. Everyone is expected to look after him/herself and his/her immediate family only. Collectivism stands for a society in which people from birth onward are integrated into strong, cohesive in-groups, which throughout people's lifetime continue to protect them in exchange for unquestioning loyalty" (2001, p. 225).

According to Triandis (1995), individualism is a social pattern that consists of loosely linked individuals who view themselves as independent from their groups and are mainly concerned with their own preferences, needs, rights, personal goals, achievements, freedom and autonomy; they emphasise rational analyses of benefits and place a low value on their relationships with others. Conversely, collectivism is a pattern of strongly linked individuals who "view themselves as a part of one or more collectives (e.g., family, tribe, co-workers)" (p. 2). Collectivism is mostly motivated by norms related to interdependence, compulsory

duties and group goals (which are given precedence over individual goals); security, group harmony and personal relationships are also important. Most important, as added by Triandis (2006), is the idea that any given culture is composed of individuals who are idiocentric (those who think, feel and behave as people in individualist cultures do) and individuals who are allocentric (those who resemble individuals in collectivist cultures). The difference in value orientation is linked to the strength of an individual's belief in key cultural values.

Power distance (PD)

PD indicates the extent to which a society accepts the fact that power in institutions and organisations is distributed unequally; it is reflected in the values of both the less powerful members of society and the more powerful members (Hofstede, 2001). This dimension is concerned with the issues of equality and inequality in a nation and with the way inequality is generally accepted (Randall, 1993). The basic issue of this dimension, according to Hofstede (2001), is "human inequality" (p. 79), which is dealt with differently among and within societies. Hofstede stated that "inside organisations, inequality in power is inevitable and functional. This inequality is usually formalised in boss-subordinate relationship" (p. 79). Thus, within the organisation as a unit of society, power inequality is necessary for control, and the distribution of power is formalised in hierarchies; pyramid-like power structures are built to solidify the relationship between managers and their subordinates.

Hofstede attempted to describe the general societal norms that create low and high power-distance patterns. There are two particular themes at play with associated work-related power-distance values. Some of the work-related values and characteristics of high power-distance countries are as follows: subordinates should not be involved in decision-making processes.

There are centralised decision structures, tall organisation is visible, managers depend on formal roles, subordinates generally behave passively

toward their managers (and are afraid or reluctant to oppose them), and subordinates often prefer more autocratic or paternalistic supervisors. In low power-distance countries, in contrast, employees prefer a more participative or consultative manager. In terms of the workplace organisation in low power-distance countries, the dominant characteristics include a decentralised decision structure, flat organisation pyramids, and managers who depend on both personal experience and their subordinates.

As described by Bochner and Hesketh (1994), high power-distance countries are generally more task- and less people-oriented because the role of a manager is to initiate structure (that is, to tell employees what to do rather than to take their opinions into account). Individuals tend to behave in a way that resembles McGregor's (1960) Theory X regarding the relationship between managers and subordinates in terms of decision-making, work ethics, and psychological contracts. Theory X states that people are naturally lazy and dislike work. Thus, managers presume that subordinates are lower, which causes subordinates to expect an exchange based on security and economic relationships more than one based on self-development (Clugston et al., 2000). Prior research has provided adequate support for the power-distance construct (e.g., Bochner and Hesketh, 1994); individuals exhibiting high PD values are less open with their superiors, are more task-oriented and show a greater tendency to believe in Theory X (which indicates that some people are inherently lazy and find work unappealing; p. 248).

A fifth dimension was included which is called long-term orientation (LTO). Long- vs. Short-Term Orientation dimension was later added to the model (Taras, Steel and Kirkman, 2012, P: 330), but it has been rarely used and could not be included in the current research due to the lack of data. Hofstede et al.'s (2008) model has recently added two more dimensions, namely, monumentalism versus self-effacement (MON) and indulgence versus restraint (IVR), to the model. To date, few studies reflect MON or IVR, so most studies must exclude them (Voss, 2012, P: 25).

Accordingly, the current study seeks to investigate whether there is a significant difference in the mean of the cultural dimensions PD, UA, I/C and M/F in public- and private-sector employees.

Methodology

Research aim and objective: The current research aims to explore the cultural dimensions presented across the different organisational levels in the Saudi Arabian public and private sectors to find out if there are any differences in the meaning of culture dimensions which could help us identify the differences in decision making process and their affects. One of the fundamental issues regarding cultural effects on organisations is that, as Hofstede (2001) stated, “there is a great lack of locally valid theories of management and organisation in which the universally human, the globally-imposed, and the culturally-specific elements will be wisely reorganised” (p. 462). Thus, there is a need for local, culturally applicable theories of management that apply to Saudi culture (particularly in a difficult global economic situation) and lead to both a high quality of public services and support of the private sector. In addition, there are centralised decision structures. Tall organisation is visible, managers depend on formal rules, subordinates generally behave passively toward their managers (and are afraid or reluctant to oppose them), and subordinates often prefer autocratic or paternalistic supervisors. In low power-distance countries, in contrast, employees prefer a more participative or consultative manager. In terms of the workplace organisation in low power-distance countries, the dominant characteristics include a decentralised decision structure, flat organisation pyramids, and managers who depend on both personal experience and their subordinates.

Questionnaire development

A questionnaire was used for data collection in this study. The cultural dimension scales used were adapted from Hofstede’s (1980) typology of cultural dimensions and have been discussed by Dorfman and Howell (1988). These scales measure various dimensions of culture: orientation towards I/C (six

items), PD, UA, and dispositions toward M/F (five items for each scale). We used a five-point Likert scale in which a score of one means “strongly disagree” and a score of five means “strongly agree.” We used the cultural dimension measurements of Clugston et al. (2000) rather than those of Hofstede (1980) because it was important to use individualised measures to consider the culture within one country; this choice allowed us to understand the degree to which variation within one country persists throughout cultural dimensions.

Appropriate modifications were introduced when the need arose to fit the measures of cultural dimensions to the Saudi context. Before the actual data collection was carried out, a pilot study was conducted in Saudi Arabia from 12 January 2010 to 15 February 2010. The pilot study aimed to obtain a high level of content validity and to ensure that the instructions, questions, and scale items were clear. The pilot study was conducted with a sample of people who were similar to the people tested in the main study (i.e., public- and private-sector employees).

The questionnaire was originally written in English. It was translated from English into Arabic using a multi-stage translation and back-translation procedure, as described by Brislin (1983). In addition, four members of the academic staff who were fluent in both spoken and written English and Arabic were given the English and Arabic versions of the questionnaire, and their feedback was requested to ensure that the meanings of all items were clear, and to ensure the internal validity of the current research method.

Sample description

The research was conducted with a random sample of employees (from the public and private sectors) from different organisational levels (senior managers, managers, and supervisors represented the top and middle management, and staff represented the lower levels) and from different organisations.

Two hundred questionnaires were distributed among four government ministries (Alhajj, Petroleum, Social Affairs, and Culture and Information) located in Jeddah, Saudi-Arabia. The sample from the private sector was collected from two Saudi companies (Juffali and Brothers Group, and Abdul Latif Jameel Co. LTD); 120 questionnaires were distributed in the private companies on 29 March 2010 and 25 April 2010. Of the public-sector employees, 135 respondents returned the questionnaire. Of the private-sector employees, 69 respondents returned the questionnaire. There were 193 completed questionnaires for the two sectors giving a 61.7% response rate. In the public sample, the

average age was 37.59 years, and the average tenure was 13.75 years. In the private sample, the average age was 36.43 years, and the average tenure was 13.45 years. The sample nationality of both sectors were Studies.

Data Analyses

The response rate for the questionnaire was satisfactory (193). To calculate the response rate, a broad definition and method of calculation for the rates of response and non-response were needed. For this purpose, we used the standard definition of response rate as defined by the Council of American Survey Research Organisations (CASRO, 1982), namely:

$$\text{Response rate} = \frac{\text{Number of completed questionnaires with responding units}}{\text{Number of eligible responding units in the sample}} = \frac{193}{320} = 60\%$$

We used the method of response-rate calculation proposed by the CASRO (1982), which assumes that the percentage of ineligible responses among the non-respondents is equivalent to that in the respondent set. Thus, when using an eligibility requirement, one first estimates the number of eligible respondents among the non-respondents. This is done using an eligibility percentage that is calculated from successfully screened individuals and applied to the non-respondents. According to these calculations, 60.0% was the estimated response rate in our study. We calculated the response rate using the CASRO approach and identified reliability values that exceeded the common thresholds (0.7) for all of the variables (e.g., Cronbach's alpha α values for PD, UA, I/C and M/F were 0.71, 0.82, 0.75 and 0.88, respectively). The data were subsequently inspected, and the construct validity was analysed. These analysis methods measured and assessed the reliability and validity using AVA and invariance analysis. To address non-response

bias issues, we collected additional data to compare to the main data. No significant major differences were found between the data sets. Based on previous research, a sample size exceeding 100 respondents can support a satisfactory SEM analysis.

First-order CFA measurement model of cultural dimensions

A first-order CFA model (Figure 1) was designed to test the multi-dimensionality of the theoretical constructs (Byrne, 2001). A model for all four cultural dimensions (i.e., M/F, PD, I/C and UA) featured 100 degrees of freedom. The results for the four-factor CFA cultural-dimension model suggest an adequate fit with the data ($\chi^2_{[100]} = 235.122$; $p < 0.05$; $\chi^2/df = 1.809$; CFI=0.92; GFI= 0.88; AGFI= 0.844; NFI = 0.83; RMR= 0.070; and RMSEA = 0.065). All of the model fit indices indicate a good fit. Before assessing the model fit indices, we measured the construct validities (e.g., standardised loadings and estimated correlations) (Table 1).

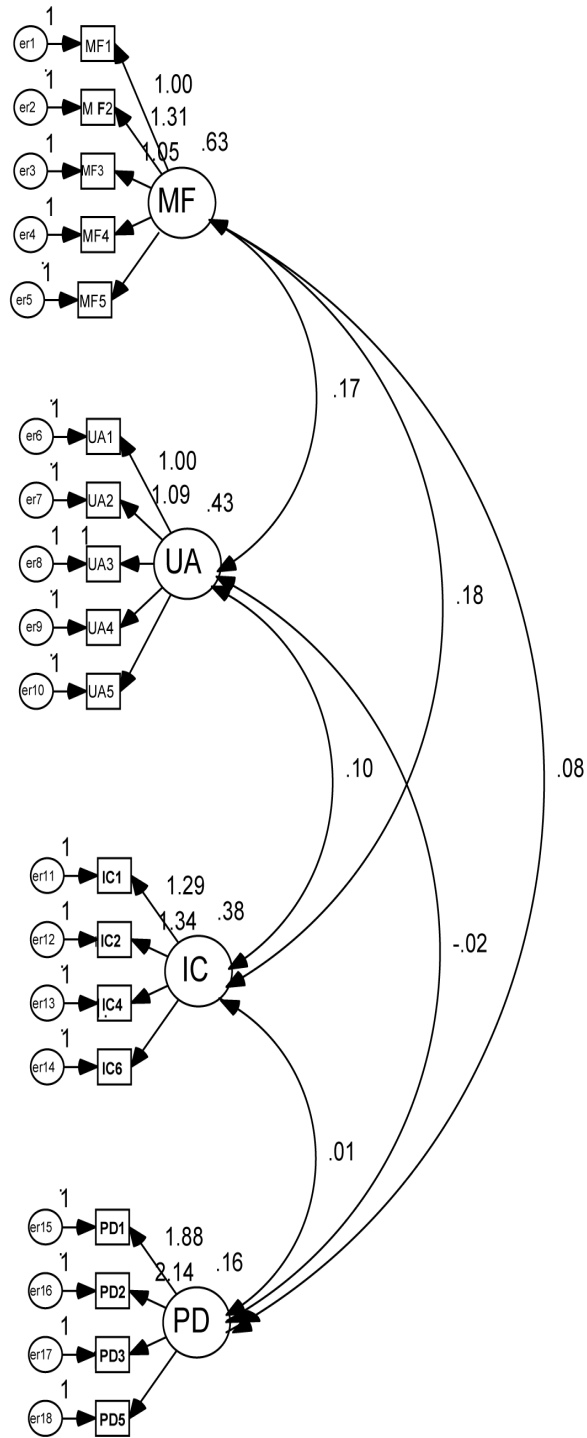

Figure 1: CFA for cultural dimensions

Dimensionality of cultural variables

CFA was conducted for each of the cultural dimensions (Table 1) indicates the fit indices and factor loadings for each cultural variable. The table shows results from separate CFAs for each cultural dimension. The factor loadings were satisfactory, and

the fit indices for each of the cultural variables were significant, except for two of the indicators of I/C (Items 3 and 5), which exhibited a cross-loading with the factor. Therefore, we removed these items from our subsequent analyses.

Table 1: Fit indices and factor loadings for each cultural variable

| Latent Variables | Observed variables | Factor loading | CR | SE | Latent Variable Model Fit Statistics | | | | | | | | | |
|--------------------------------------|--------------------|----------------|--------|------|--------------------------------------|------------------|----|-------|------|------|------|------|------|-----|
| | | | | | R ² | Chi ² | df | RMSEA | CFI | GFI | AGFI | NFI | PGFI | AVE |
| Masculinity/ Femininity (M/F) | X ₁ | .716*** | 12.25 | .064 | .482 | 12.844 | 5 | .070 | .984 | .973 | .920 | .974 | .324 | .71 |
| | X ₂ | .786*** | 12.71 | .058 | .614 | | | | | | | | | |
| | X ₃ | .774*** | 14.10 | .060 | .515 | | | | | | | | | |
| | X ₄ | .847*** | 15.34 | .075 | .618 | | | | | | | | | |
| | X ₅ | .863*** | 16.35 | .070 | .670 | | | | | | | | | |
| Uncertainty Avoidance (UA) | X ₁ | .766*** | 12.10 | .079 | .476 | 25.206 | 6 | .129 | .944 | .948 | .910 | .929 | .379 | .74 |
| | X ₂ | .815*** | 11.85 | .047 | .490 | | | | | | | | | |
| | X ₃ | .701*** | 12.58 | .061 | .357 | | | | | | | | | |
| | X ₄ | .702*** | 11.32 | .095 | .481 | | | | | | | | | |
| | X ₅ | .652*** | 10.26 | .082 | .653 | | | | | | | | | |
| | X ₆ | .610*** | 12.43 | .075 | .528 | | | | | | | | | |
| Individualism/ Collectivism (I/C) | X ₁ | .766*** | 5.047 | .169 | .361 | 16.457 | 5 | .070 | .946 | .971 | .943 | .931 | .477 | .68 |
| | X ₂ | .862*** | 5.943 | .140 | .203 | | | | | | | | | |
| | X ₃ | .505*** | 5.854 | .129 | .216 | | | | | | | | | |
| | X ₄ | .516*** | 6.137 | .131 | .197 | | | | | | | | | |
| | X ₅ | .601*** | 5.891 | .158 | .437 | | | | | | | | | |
| | X ₆ | .701*** | 4.707 | .152 | .284 | | | | | | | | | |
| Power Distance (PD) | X ₁ | .797*** | 15.180 | .064 | .422 | 3.104 | 2 | .054 | .992 | .991 | .960 | .979 | .198 | .56 |
| | X ₂ | .689*** | 13.609 | .060 | .475 | | | | | | | | | |
| | X ₃ | .862*** | 9.902 | .047 | .692 | | | | | | | | | |
| | X ₄ | .719*** | 13.361 | .072 | .409 | | | | | | | | | |
| | X ₅ | .730*** | 17.404 | .059 | .673 | | | | | | | | | |

N= 193; p**<.01; p***<.001, The GFI measures the relative amount of covariance and variance collectively accounted for by the model. The parsimonious normalised fit index (PNFI) is used to measure parsimonious fit, and the normalised fit index (NFI) is used to compare the fit of the model to the null model when all variables are assumed to be independent (Bentler and Bonett, 1980). Browne and Cudeck (1993) suggest that a root mean square error of approximation (RMSEA) value of 0.08 or less would indicate an acceptable model fit.

Our modification indices suggest that the error terms observed between the fourth and fifth items of the I/C dimension (“employees should only pursue their goals after considering the best interests of the group” and “managers should encourage group loyalty even at the expense of an individual’s goals”) were significantly correlated. A careful examination of these two indicators revealed that their meanings were too similar, producing a high error of correlation. Consequently, these items were omitted from further analyses. Similarly, the fifth and sixth (PD) indicators exhibited cross-loading, so they were also discarded.

To assess convergent validity, we examined whether each indicator’s loading on its posited construct was greater than twice its standard error and whether each

factor loading was greater than 0.5 (Anderson and Gerbing, 1988). For the four constructs, all items were found to load significantly on their respective constructs, and the factor loadings were greater than twice the standard error. The factor loadings also all exceeded 0.5. The AVE values, which ranged from 0.56 to 0.74, all exceeded the recommended value of 0.5 (Hair et al., 2006; Tabachnic and Fidell, 2007). These results indicate that convergent validity exists for the hypothesised measurement model. In the case of discriminant validity, the estimated correlations among the four factors ranged from 0.076 to 0.179 (Table 2), all of which were statistically significant ($p < 0.05$) and below the recommended value of 0.85 (Kline, 1998).

Table 2: Correlations among the four cultural dimension factors .

| | | | Estimate | S.E. | C.R. | P | Label |
|-----|------|-----|----------|------|-------|------|-------|
| M/F | <--> | UA | .168 | .047 | 3.555 | *** | Lab2 |
| M/F | <--> | I/C | .179 | .051 | 3.516 | *** | Lab1 |
| M/F | <--> | PD | .076 | .033 | 2.270 | .023 | Lab4 |
| UA | <--> | I/C | .103 | .039 | 2.640 | .008 | Lab3 |
| I/C | <--> | PD | .007 | .023 | .283 | .777 | Lab5 |
| UA | <--> | PD | -.020 | .024 | -.845 | .398 | Lab6 |

***Correlation is significant at the 0.01 level (two-tailed).

We identified a significant correlation between the four dimensions with a significance of 0.001. Only the PD dimension exhibited no correlation with I/C, although it did correlate positively with the M/F dimension (Table 2 and Figure 1). Moreover, the literature does not indicate that any one of these dimensions is antecedent to the others (Clugston et al., 2000). To summarise, our results support the discriminate validity of the constructs in our measurement model.

Cultural value level

We aimed to explore the cultural dimensions present across the different organisational levels in

the Saudi Arabian public and private sectors. The mean scores of the culture dimensions of public- and private-sector organisations are listed in Table 3.

Table 3 indicates that, in the public sector, the highest average cultural dimension score was for UA (4.109) and the lowest mean was for PD (2.056). The mean scores for I/C and M/F were 3.796 and 3.496, respectively. However, in the private-sector organisations, the average cultural dimension scores for UA and I/C were similar (3.753 and 3.731, respectively). The score for M/F was 3.212, and the lowest mean was for PD, at 2.556.

Table 3: Mean score of culture dimensions for public and private organisations

| Dependent Variable | TYPE_ORG | Mean | Std. Error | 95% Confidence Interval | |
|--------------------|-------------|-------|------------|-------------------------|-------------|
| | | | | Lower Bound | Upper Bound |
| PD | PUBLIC ORG | 2.056 | .064 | 1.930 | 2.183 |
| | PRIVATE ORG | 2.556 | .087 | 2.385 | 2.728 |
| UA | PUBLIC ORG | 4.109 | .068 | 3.975 | 4.243 |
| | PRIVATE ORG | 3.753 | .092 | 3.572 | 3.934 |
| IC | PUBLIC ORG | 3.796 | .068 | 3.662 | 3.930 |
| | PRIVATE ORG | 3.731 | .092 | 3.550 | 3.913 |
| MF | PUBLIC ORG | 3.453 | .088 | 3.279 | 3.627 |
| | PRIVATE ORG | 3.212 | .119 | 2.977 | 3.448 |

We have used one-way ANOVA to identify any significant differences in cultural dimensions between public- and private-sector employees at the various organisational levels. Table 4 summarises the main ANOVA findings for cultural dimensions among the two sector groups. For Table 4, the F-ratio was derived

by separating the mean squares from the effect of the residual mean squares (Field, 2005). There were significant differences between sectors at that degree in two dimensions: PD ($F(21,368) = 10.336, p < 0.01$) and UA ($F(9,733) = 5.251, p < 0.01$).

Employees in the higher-level group exhibited the highest average UA in both sectors, and the differences between this group and the other groups were significant ($p < 0.05$). However, the other two

dimensions (collectivism and masculinity) showed no differences among the employees in public and private organisations.

Table 4: F tests of the effect YPE _ ORG.

| Dependent Variable | | Sum of Squares | df | Mean Square | F | Sig. | Partial Eta Squared |
|--------------------|----------|----------------|-----|-------------|--------|------|---------------------|
| PD | Contrast | 10.336 | 1 | 10.336 | 21.368 | .000 | .107 |
| | Error | 86.585 | 191 | .484 | | | |
| UA | Contrast | 5.251 | 1 | 5.251 | 9.733 | .002 | .052 |
| | Error | 96.579 | 191 | .540 | | | |
| IC | Contrast | .173 | 1 | .173 | .320 | .572 | .002 |
| | Error | 96.684 | 191 | .540 | | | |
| MF | Contrast | 2.393 | 1 | 2.393 | 2.633 | .106 | .014 |
| | Error | 162.661 | 191 | .909 | | | |

This test is based on linearly independent pairwise comparisons estimated marginal means

Discussion

Hofstede's index identifies four cultural dimensions and combines them to assign an aggregate score. Therefore, it is possible to use judicious comparisons to differentiate between cultural orientations within a given dataset. However, there are major issues associated with the use of Hofstede's index. First, researchers have often relied on Hofstede's (1980) results without considering cultural changes that may have occurred during the past 30 years (McCoy, Everard, and Jones, 2005). Second, Hofstede designed his index so that the scores for a country would ideally fall between 0 and 100. However, it is not uncommon for some countries to score higher than 100.

Although Hofstede's work reflects an "ecological" level of analysis, correlations among the items in each scale and factor analyses used to classify the measures employ mean scores from respondents that are aggregated at the national level before they are subjected to analysis. In addition, each item in Hofstede's questionnaire produces a single data point (the mean score) for each country in his analysis. Analysis at the individual level reveals a completely different perspective than analysis at the ecological level (Dorfman and Howell, 1988, p. 129). For instance, the relationships among the three items measuring PD in Hofstede's work (2001) are significant only at the

national level, whereas the same correlations at the individual level of analysis are almost zero.

In this research, some of the mean scores were similar to Hofstede's original data, whereas others were different. However, these results do not necessarily mean that the cultures in these countries are changing. Hofstede constructed his index after studying employees of IBM, a single, large multinational corporation. Critics have argued that this limitation led to significantly biased country scores, as two samples drawn from one country may result in different scales. Triandis (1995) cogently argued that people within the same country may exhibit different cultural orientations. Finally, Hofstede's measures can only indicate the aggregate cultural orientation of a group; it does not allow one to distinguish between the idiosyncrasies of individuals within a sample.

This research has addressed two main issues related to cultural dimensions: a confirmation of the multi-dimensionality of cultural dimensions and an investigation of differences in the level of these personal cultural values between two sectors (which allows for the investigation of their effects on work behaviours using individual-level analysis). The results of the CFA confirmed the multi-dimensionality of the cultural factors. The results also confirmed that two of the cultural values are significantly different between employees in separate sectors.

Our results for the public sector indicate that the highest average cultural dimension score was for UA (4.109) and that the lowest mean was for PD (2.056). The mean scores for I/C and M/F were 3.796 and 3.453, respectively. From these average scores, we can conclude that Saudi public-sector employees exhibit a high level of UA and a moderate-to-high degree of individualism and masculinity. In contrast, the mean PD score was relatively low.

Masculinity/Femininity (M/F)

Regarding M/F, Hofstede's (2001) index for Arab countries, including Saudi Arabia, was 53. This result indicates that Saudi Arabian society exhibits a masculine cultural orientation. AlQurashi (2009) reported results that also indicated a high mean score for M/F (3.47 out of 5.00). Therefore, our results agree with the previously established notion that Saudi society is more masculine; in other words, the high scores indicate an acceptance of masculine work goals. However, the results from Hofstede's index indicate that Arab countries lie midway between Canada and Belgium with regards to M/F and suggest that, following the significant correlations mentioned above, there are no significant differences in the mean score of M/F between public and private organisations.

Uncertainty Avoidance (UA)

AlQurashi (2009) found that UA is higher in public organisations (i.e., a higher level of organisation) than in private ones. Our results support this finding, as UA in the public sector was significantly different from UA in the private sector (4.109 and 3.753, respectively).

Individualism/Collectivism (I/C)

With regards to I/C, no significant differences were observed between the public and private sectors, and the results suggest that the I/C level was almost the same for the two sectors (with mean scores of 3.796 and 3.731, respectively).

Power distance (PD)

Invariance analysis shows that PD in the private sector is significantly different from that observed in the public sector. Unexpectedly, the results showed a higher level of PD in the private sector as compared to

the public sector. The PD mean score was higher in the private sector than in public organisations (2.056 and 2.556, respectively). Our results support AlQurashi's (2009) conclusion that public sector organisations exhibit a low level of PD.

These findings are consistent with those of previous studies conducted in the Middle East (Bjerke and Al-Meer, 1993; Cohen, 2007). The rather unexpected results regarding high masculinity, with an average score of 3.470, suggest that the Saudi culture may exhibit a more "macho" orientation and a relatively high level of individualism, given the average score of 3.715 for this scale. Employees at the highest organisational level showed the highest average UA, and the differences between this group and the other two groups were significant. However, the other three dimensions (PD, I/C and M/F) showed no differences among the two groups (public and private) of employees at different organisational levels.

With regard to M/F, Hofstede's (2001) index for Arab countries, including Saudi Arabia, was 53. Therefore, it was slightly above the mid-point, as the index ranges from 0 to 100. Bjerke and Al-Meer (1993) obtained different results, with a score of 43 for Saudi Arabia, placing it on the feminine side, along with Iran and Turkey (43). However, At-Twajiri and Al-Muhaiza (1996) conducted more recent research using Hofstede's formulas to measure cultural dimensions; they indicated that Saudi Arabia was more masculine, with an index of 53. This result indicates that Saudi Arabia tends towards a masculine cultural orientation (Table 5). As mentioned earlier, our results also indicated a relatively high mean score for M/F (3.453 out of 5.00). Another reason for these results could be that 91.9% of the respondents were male. In sum, our results support the notion that the Saudi sample scored relatively high in the masculine work value. Based on Hofstede's index, which indicates that Arab countries lie midway between Canada and Belgium in the M/F dimension, no significant differences were found between the two sectors.

Table 5: Hofstede's cultural dimension scores in Arab countries (KSA)

| Cultural dimension | | Hofstedeindex for Arab countries | At-Twajjri and Al-Muhaiza (1996) index for Saudi Arabia | Mean score of cultural dimensions in AlQurashi (2009) study* |
|--------------------|--------------|----------------------------------|---|--|
| (M/F) | <i>Index</i> | 53 | 53 | 3.47 |
| | <i>Rank</i> | 23 | | |
| (UA) | <i>Index</i> | 68 | 88 | 4.03 |
| | <i>Rank</i> | 27 | | |
| (I/C) | <i>Index</i> | 38 | 41 | 3.72 |
| | <i>Rank</i> | 26-27 | | |
| (PD) | <i>Index</i> | 80 | 61 | 2.07 |
| | <i>Rank</i> | 7 | | |

* Total mean score is out of 5 on a Likert-type scale measure.

Hofstede (2001) defined UA as the degree to which people feel threatened by uncertain and ambiguous situations and seek to avoid them. He argued that, when individuals encounter high uncertainty, they seek job security and prefer formal rules; such individuals tend to have longer job tenures and exhibit weaker intentions to leave their employer, and they ultimately earn higher average seniority in their jobs. Our results provide full support for AlQurashi (2009), as UA was significantly higher in the public sector than in the private sector.

Our data revealed a total mean UA score of 4.109, indicating that Saudi Arabia is a risk-averse society. This is consistent with the results of At-Twajjri and Al-Muhaiza(1996); their study also revealed a higher score for UA. One of their justifications for this finding was that an increase in the standard of living in Gulf Cooperation Council countries (GCC) such as Saudi Arabia has led to an increased fear of losing that wealth. In addition, fluctuations in the price of oil are a principal

concern for these countries because the revenue from oil sales is the main source of government funding, so economic planning is affected by those fluctuations. In fact, before oil was discovered in Saudi Arabia, life in Saudi society was simple; the Saudi people had nothing to lose because they were already faced with difficult living circumstances. However, they have now built up greater capital reserves than other nearby countries, and thus, the UA has increased. Even in the public sector, in which job security is higher than in the private sector, employees are risk-avoidant.

The mean score for I/C in our data was relatively high for the public and private sectors (3.796 and 3.731 out of 5.0, respectively), and these results appear to contradict the Hofstede index, which describes Arab countries as generally collectivistic societies (Table 5). Saudi society, however, displays a tendency towards individualism relative to other Arab countries.

The invariance analysis between public and private I/C was insignificant, and the results suggest

that there are no significant differences in the I/C culture dimension between the public and private sectors. These results were not unexpected, as the I/C mean score was relatively high for the Saudi sample (AlQurashi, 2009). However, one explanation for a high level of I/C in both public and private organisations may be that, as claimed by Triandis (1995, p. 36), “in a collectivist society there are idiocentrics (collectivists) who look for the earliest opportunity to escape the oppression of their groups, and in individualist societies there are allocentrics (individualistic) who reject individual pursuits and join gangs, clubs, communes and other collectives.” Thus, within one country, individuals display considerable variation with respect to measurements of I/C. Another explanation for this variation may be cultural changes. Moreover, Hofstede has indicated that the degree of individualism in a country is statistically related to that country’s wealth; thus, if wealth has enabled the Saudis to enjoy a comfortable life, it may also be expected to decrease their reliance upon one another.

However, modern Arab management practices have been influenced by religious, tribal and family traditions. The result of these influences has been a combination of family and tribal norms in addition to a bureaucratic organisational structure (House et al., 2004, p. 63). Thus, these aspects still influence Saudi public employees and could explain the fact that both tendencies exist in employees: traditional values associated with social forces, and the tendency for people to look after themselves and their immediate family only.

The results reveal that there are significant differences between the PD level in public and private sectors, with the unexpected result that PD in the private sector is significantly higher than in the public sector (2.556 and 2.056, respectively). The mean PD score for our Saudi sample was 2.07, whereas in Hofstede’s index, Arab countries were high-PD nations with an index score of 80. According to Hofstede, PD is the extent to which a society accepts an unequal distribution of power in institutions and organisations.

At-Twajri and Al-Muhaiza (1996) used Hofstede’s formulation to measure the four dimensions of culture and also found PD to be low with an index of 61 versus Hofstede’s index of 80 (Table 5). This shift may be related to the fact that Hofstede’s study commenced over thirty-five years ago, whereas the data for the current study were collected in 2010 as social changes were occurring in Saudi Arabia. For example, the government has recently established the Al-Shura Council, which is a body of consultative assemblies in which important issues are discussed before reaching decisions. Although just one example, this event indicates that Saudis are moving in the direction of decentralised decision-making and thus reducing the conditions for high PD. Moreover, many Saudis have more exposure to Western education and interact with different cultures; therefore, while employees and managers in the past behaved according to traditional cultural patterns, this new exposure would be expected to reduce the tendency towards PD among them.

The ANOVA test revealed significant differences in uncertainty avoidance (UA) at the higher levels of job seniority. This indicates that top-level managers in the Saudi public sector are uncertainty avoiders. In fact, the Saudi sample exhibited a high level of UA. The Saudi public sector employee sample obtained high to moderate scores from individual measures of masculinity and individualism, showing to be a more masculine and individualistic society, which, as Hofstede indicates, could be related to the degree of individualism in a country and its statistical relationship to that country’s wealth. Our results also revealed that power distance (PD) has decreased in comparison with Hofstede’s study and is consistent with the recent study by At-Twajri and Al-Muhaiza (1996). This observation is a consequence of the change in lifestyle of the GCC populations and the increasing contact with the West. (AlQurashi, 2009)

Conclusion

An important finding is the strong support for Hofstede’s cultural dimensions, not only in

distinguishing environments across nations, but also within a homogenous work-setting within one country.

Attention to Hofstede's cultural dimensions should allow practitioners to integrate training and communication into organisation policy. However, these results should not only attract public managers in the field to take on some challenges but should also encourage future researchers to investigate these issues more intensively. .

As Chew and Putti (1995) pointed out, employees' high aversion to risk may reflect an unwillingness to deal with further uncertainty because of a fear of failure. This idea reflects the strong relationship between UA and sacrifice and is indicative of a greater long-term commitment to their organisation (AlQurashi, 2009). As suggested by Hofstede, one strategy for dealing with this matter could be to introduce planning and control systems that deal with the processes reflecting basic organisational principles and values, in an attempt to reduce UA.

Strategic planning should focus on planning and controlling processes in public organisations that reflect the basic principles that guide employees in their work and avoid any surprises, as Hofstede suggested. The government has long-term development plans, but we propose that the existence of an effective planning and control system for each ministry, with a clear vision, would improve the norms of public organisations. High UA is a possible indicator that strategic planning is not being practised. Therefore, the encouragement of requirements for more specificity in planning and more short-term feedback could involve experts in the planning process, who might predict how these plans could decrease uncertainty among staff. Furthermore, high UA is the result of an overly restricted view of related information. Employees need more details about rules and procedures for handling different situations. As At-Twajiri and Al-Muhaiza (1996) pointed out, everyone in the organisation should know who reports to whom. Formal lines of communication run vertically, meaning that management can reduce UA by emphasising who has authority over whom.

In GCC countries, individuals are generally required to go to the top of the pyramid to have their papers processed, their requirements considered or their objections resolved.

According to AlQurashi (2009), UA affects role performance both directly and indirectly. This conclusion provides further evidence that, to the extent that employees have sufficient and clear information regarding their job description (which describes and explains the requirements of specific jobs and what is expected from employees to perform at high levels), the organisation will prosper.

Therefore, job designs that account for a desire for high achievement would increase the intrinsic motivation of employees. The provision of some type of autonomy to their work, together with motivation, would satisfy the assertiveness and determination needs of employees. However, individualism has a strong relationship with both emotional attachment and obligation to an employee's organisation. These relationships suggest that employees form attachments based on the satisfaction of some extrinsic need: security, advancement and/or ambition. Management can utilise this work value to improve employee commitment and consequently the productive behaviour of employees. At the same time, religion, Islamic principles and tribal influences emphasise the concepts of caring and cooperation between employees.

Finally, the acts of consulting and sharing ideas with employees decentralise decision-making structures. This decentralisation would not negatively affect emotional attachment or obligation. Consultative management may lead to improved role performance and increased levels of commitment.

References

1. Anderson, J.C. and Gerbing, D.W. (1988) "Structural equation modelling in practice: A review and recommended two-step approach", *Psychological bulletin*, vol. 103, no. 3, pp.411-423.
2. AlQurashi, S.M. (2009) "An investigation in

- antecedents and consequences of organisational commitment among government administrative employees in Saudi Arabia”, PhD thesis, Brunel University, London, UK.
3. Anderson, J.C. and Gerbing, D.W. (1988) “Structural equation modelling in practice: A review and recommended two-step approach”, *Psychological bulletin*, vol. 103, no. 3, pp.411-423.
 4. At-Twajjri, M.I. and Al-Muhaiza, I.A. (1996) “Hofstede’s cultural dimensions in the GCC countries: An empirical investigation”, *International Journal of Value-Based Management*, vol. 9, no. 2, pp. 121-131.
 5. Bearden, W.O., Money, R.B. and Nevins, J.L. (2006) “Multidimensional versus unidimensional measures in assessing national culture values: The Hofstede VSM 94 example”, *Journal of Business Research*, vol. 59, no. 2, pp. 195-203.
 6. Bochner, S. and Hesketh, B. (1994) “Power distance, individualism/collectivism, and job-related attitudes in a culturally diverse work group”, *Journal of Cross-Cultural Psychology*, vol. 25, no. 2, pp. 233-257.
 7. Bjerke, B. and Al-Meer, A. (1993) “Culture’s consequences: management in Saudi Arabia”, *Leadership and Organisation Development Journal*, vol. 14, no. 2, pp. 30-35.
 8. Brislin, R.W. (1980) “Translation and content analysis of oral and written material”, *Handbook of cross-cultural psychology*, vol. 2, pp. 389-444.
 9. Bryman, A. (1995) *Research Methods and Organisation Studies*. London: Unwin Hyman Ltd.
 10. Cohen, A. (2007) “An Examination of the Relationship Between Commitments and Culture Among Five Cultural Groups of Israeli Teachers”, *Journal of Cross-Cultural Psychology*, vol. 38, no. 1, pp. 34.
 11. Cohen, A. and Keren, D. (2008) “Individual Values and Social Exchange Variables: Examining Their Relationship to and Mutual Effect on In-Role Performance and Organisational Citizenship Behaviour”, *Group and Organisation Management*, vol. 33, no. 4, pp. 425-452.
 12. Council of American Survey Research Organisations. (1982) *On the Definition of Response Rates*, CASRO Special Report, The Council of American Survey Research Organisations, Port Jefferson, NY.
 13. Chew, I.K.H. and Putti, J. (1995) “Relationship on work-related values of Singaporean and Japanese managers in Singapore”, *Human Relations*, vol. 48, no. 10, pp. 1149-1170.
 14. Clugston, M., Howell, J.P. and Dorfman, P.W. (2000) “Does Cultural Socialization Predict Multiple Bases and Foci of Commitment?”, *Journal of Management*, vol. 26, no. 1, pp. 5.
 15. Dorfman, P.W. and Howell, J.P. (1988) “Dimensions of national culture and effective leadership patterns: Hofstede revisited”, *Advances in International Comparative Management*, vol. 3, no. 127-150.
 16. Field, A.P. (2005) *Discovering Statistics Using SPSS*. California: Sage Publications Inc.
 17. Fischer, O. and Al-Issa, A. (2012) “In for a surprise piloting the Arab version of the VSM 94”, *International Journal of Intercultural Relations*, Volume 36, Issue 5, September 2012, Pages 737–742.
 18. Gelade, G.A., Dobson, P. and Gilbert, P. (2006) “National Differences In Organisational Commitment: Effect of Economy, Product of Personality, or Consequence of Culture?”, *Journal of Cross-Cultural Psychology*, vol. 37, no. 5, pp. 542-556.
 19. Gelade, G.A., Dobson, P. and Auer, K. (2008) “Individualism, masculinity, and the sources of organisational commitment”, *Journal of Cross-Cultural Psychology*, vol. 39, no. 5, pp. 599-617.
 19. Hair, J., Black, W., Babin, B., Anderson, R. and Tatham, R. (2006) *Multivariate data analysis*, Sixth edn, Pearson Education Inc, Upper Saddle River, New Jersey.
 20. Hofstede, G. (1998) “Attitudes, values and organisational culture: disentangling the

- concepts”, *Organisation Studies*, vol. 19, no. 3, pp. 477-493.
21. Hofstede, G. and McCrae, R.R. (2004) “Personality and culture revisited: Linking traits and dimensions of culture”, *Cross-Cultural Research*, vol. 38, no. 1, pp. 52-88.
 22. Hofstede, G.H. 1980. *Culture’s consequences: International differences in Work-Related values*. London: Sage Publications.
 23. Hofstede, G.H. (2001) *Culture’s Consequences: Comparing Values, Behaviours, Institutions, and Organisations Across Nations*. 2ndedn. California: Sage Publication.
 24. House, R.J.; Leadership, G.; Hanges, P.J.; Javidan, M.; Dorfman, P.W.; Gupta, V., (2004) *Culture, leadership, and organisations: The GLOBE study of 62 societies*, CA: Sage Publication.
 25. Kline, R.B. (1998) *Principal and practice structural equation modelling*. 1stedn. New York: Guildford Press.
 26. Kirkman, B. L and Shapiro, D, L. (2001) “The Impact of Cultural Values on Job Satisfaction and Organisational Commitment in Self-Managing Work Teams: The Mediating Role of Employee Resistance”, *The Academy of Management Journal*, vol. 44, no. 3, pp. 557-569.
 27. McCoy, S., Everard, A. and Jones, B. (2005) “An examination of the technology acceptance model in Uruguay and the US: A focus on culture”, *Journal of Global Information Technology Management*, vol. 8, no. 2, pp. 27-45.
 28. McGregor, D. (1960) *The human side of enterprise*. New York: McGraw-Hill.
 29. Randall, D.M. (1993) “Cross-cultural research on organisational commitment: A review and application of Hofstede’s value survey module”, *Journal of Business Research*, vol. 26, no. 1, pp. 91–110.
 30. Schwartz, S.H. (1999) “A Theory of Cultural Values and Some Implications for Work”, *Applied Psychology*, vol. 48, no. 1, pp. 23-47.
 31. Tabachnick, B. and Fidell, L. (2007) *Using multivariate statistic*. 5thedn. Essex. England: Pearson Education, Inc.
 32. Taras, V, Steel. P and Kirkman . B .L (2012) Improving national cultural indices using a longitudinal meta-analysis of Hofstede’s dimensions, *Journal of World Business*, Volume 47, Issue 3, July 2012, Pages 329–341.
 33. Triandis, H.C. (1995) *Individualism and Collectivism*. New York: West view Press, Inc.
 34. Triandis, H.C. (2006) “Cultural aspects of globalization”, *Journal of International Management*, vol. 12, no. 2, pp. 208-217.
 35. Tyler, T.R., Lind, E. A and Huo, Y. J, (2000) “Cultural values and authority relations: The psychology of conflict resolution across cultures”, *Psychology, Public Policy, and Law*, Vol. 6, no.4, pp. 1138-1163.

القيم الثقافية لدى المديرين والمرؤوسين: دراسة مقارنة لأبعاد هوفستيد الثقافية بين القطاع العام والقطاع الخاص في المملكة العربية السعودية

سوزان بنت محمد القرشي

أستاذ الإدارة العامة والسلوك التنظيمي المساعد

قسم الإدارة العامة / كلية الاقتصاد والإدارة

جامعة الملك عبدالعزيز / جدة

SALQURASHI@kau.edu.sa

(قدم للنشر في ٢٨ / ٧ / ١٤٣٣ هـ، وقبل للنشر في ٣ / ٣ / ١٤٣٤ هـ)

الكلمات المفتاحية : الأبعاد الثقافية لهوفستد ، تفاوت القوة ، تجنب عدم التأكد، الفردية مقابل الجماعية ، الذكورية مقابل الأنوثة

ملخص البحث. لقد تم استخدام أبعاد هوفستيد الثقافية المرتبطة بالعمل كنموذج بحثي في مجال الإدارة. وقد أثر تصنيفه للبلدان بناءً على القيم الثقافية الأربع المرتبطة بالعمل التي تشمل تفاوت السلطة، تجنب عدم التأكد، الذكورة مقابل الأنوثة، الفردية مقابل الجماعية، على كثير من الدراسات الخاصة بالقيم الثقافية. وبناءً على مقترح هوفستيد فإن الدراسة الحالية تستقصى الاختلافات في ثقافة العمل بين منظمات القطاع العام والقطاع الخاص في المملكة العربية السعودية باستخدام عينة مكونة من ٣٢٠ موظفاً من مختلف مستويات المنظمة (تم أخذها من أربع وزارات سعودية وشركتين من شركات القطاع الخاص). وقد اتضح من التحليل العاملي التوكيدي (CFA) تدعيم تعدد الأبعاد الثقافية لهوفستد. وقد أوضحت النتائج مستوى كل بعد من الأبعاد الأربعة في القطاعين. كما أن النتائج تركز بصورة خاصة على الفروقات ذات الدلالة بين المجموعات في بعدين هما تجنب عدم التأكد و تفاوت القوة. كما استخلصت النتائج أيضاً العديد من القضايا تتعلق بالأبعاد الثقافية التي تؤثر في سلوك الموظفين. ومن بين هذه النتائج درجة تجنب عدم التأكد العالية التي تمت ملاحظتها لدى مديري المستويات العليا من التنظيم في القطاع العام السعودي. كما توضح النتائج أيضاً عن وجود فروقات ذات دلالة احصائية بين مستوى مسافة القوة في القطاعين العام والخاص، مع نتيجة غير متوقعة هي أن مسافة القوة في القطاع الخاص أعلى بصورة ذات دلالة بالمقارنة مع القطاع العام. هذه النتائج تتسم بتداعيات هامة بالنسبة لطبيعة صناعة القرار والإدارة بين موظفي الحكومة وموظفو القطاع الخاص في المملكة العربية السعودية وبلدان مجلس تعاون الخليج ككل. ومن بين النتائج الهامة الدعم القوي الذي حظيت به أبعاد هوفستيد الثقافية، ليس في البيئات المتمايزة في البلدان المختلفة فحسب بل أيضاً في بيئة العمل المتجانسة في البلد الواحد.