

Solar Energy Utilization in Greenhouse Tomato Production

Ali M.S. Al-Amri

*Agricultural Engineering Department, King Faisal University, P.O. Box 4421
Al-Hasa 31982, Saudi Arabia*

(Received 29/7/1415; accepted for publication 22/6/1416)

Abstract. This research project aims to study the possibility of utilizing solar energy systems in heating the interior ambient air of gable even-span greenhouses. A section of the southern inclined roof of an experimental greenhouse is employed as a solar water heater to supply hot water. The solar heating process during night time is needed to maintain an optimum air temperature (18C). An arithmetic programme is employed to estimate the solar radiation flux incident on the surface of the greenhouse. The thermal performance of the heating system is measured, tested and computed using series of equations. Results of the experimental work show that the specific approach of heating the greenhouse for tomato production enhances the rate of growth and increases the fresh tomato yield by 46.67% (for winter crop) in comparison with the commercial greenhouse (large size greenhouses) of the same research station. Therefore, the specific approach of heating the greenhouse can be utilized for protected cropping. The area of the solar water heater can be assessed according to the area of ground surface, incoming solar radiation and the temperature difference between the inside and the outside of the greenhouse.

Introduction

The problems facing greenhouse growers in Saudi Arabia are a direct result of high costs of production that have not been alleviated by corresponding increased returns [1]. Most growers have absorbed in part the higher costs and have made great advances in yield and quality of produce. The decreased profit margins, however, have made new greenhouse construction less and less attractive. This is especially true in the light of the continued increase in fuel and electricity costs and the reduced certainty of future availability of the large amount of fossil fuels required to heat existing greenhouses. It is clear that steps must be taken to make greenhouses more energy efficient and less dependent on fossil fuel energy supplies [1].

As energy conservation schemes for greenhouses are implemented and greenhouse crops become more competitive with imports, profit margins need to be restored, if new greenhouse construction is to regain momentum [2]. Designers will be called upon to produce new, energy-efficient designs that make maximum use of solar energy and are compatible with energy conservation systems and changing cultural practices and crop varieties.

There is a great dearth of information regarding greenhouse tomatoes and cucumbers grown in tropical and subtropical climates [1]. Such information could be used to improve the greenhouse vegetable production industry in the Kingdom of Saudi Arabia [1]. In fact, photosynthesis, respiration, and other essential plant processes involve many chemical reactions that are mainly affected by the plants environment [3, p.56].

Greenhouses are constructed and operated to provide an acceptable plant environment that will contribute to a profitable enterprise. Environmental production problems in the eastern province of Saudi Arabia are associated with high humidity and temperature of ambient air in summer and vice versa in winter. Typically and conventionally, greenhouse tomatoes in Saudi Arabia are planted in October or November and grow through June with harvest beginning as early as February [1]. During the growing season the interaction between ambient weather and the grower-managed greenhouse environments affect: (1) the timing of initiation of fruiting, (2) size and quality of the fruit, and (3) total yield. The dramatic decrease in the ambient air temperature (particularly at night) during winter season and vice versa in summer may be considered as one of the biggest problems in Saudi Arabia's greenhouse vegetable production industry [1].

The use of mathematical models to simulate the profitability of various management strategies is employed [4]. Simulation models of crop systems have been developed to predict crop growth, development, and yield from input data on the characteristics of a variety crops and weather [5]. Models have also been developed that predict greenhouse environmental conditions from ambient climatic and control system inputs [2,6,7]. Combined crop and greenhouse models have allowed optimal control strategies for particular circumstances to be evaluated [8,9]. Ultimately these simulation models can be incorporated into dynamic, flexible computerized control systems [10] and linked to heuristic knowledge bases [11-14]. Such systems seem appropriate for controlling greenhouse environments.

The main objective of this research work is the development of a heating system for greenhouse tomato production under cold climate, and more specifically, to determine the design parameters of greenhouses which influence heating system effectiveness.

Experimental Facilities

Experimental greenhouse design

An experimental greenhouse (gable even-span) is designed, constructed and installed at the Agricultural and Veterinary Research Station of King Faisal University (Saudi Arabia). The gross dimensions of the new design of the polyethylene greenhouse are 8.0 m long, 4.0 m wide, and 3.10 m height, with a net floor surface area of 32.0 m². The greenhouse structural frame is formed from the water-galvanized pipes (2 inch diameter). The rafter length is 2.28 m, and gable height is 1.10 m (1 inch diameter), while the height of each side wall is 2.0 m. The rafters are inclined at 28.8° (the inclination of the rafters may be greater than the latitude angle of the place in question by 14%, Al-Ahsa's latitude angle is 25.3° [1]) to minimize the side effects of wind-load on the roof of the greenhouse. The side walls are strongly connected to concrete foundations. In order to transfer gravity uplift and overturning loads (such as those from crop, suspended equipment and wind) safely to the ground, twenty tensile wires are tied and fixed throughout the rafters and vertical pipes are located in each side in order to increase and maintain the durability of the structural frame and plastic cover. The greenhouse is oriented in an east-west direction and covered using 0.1 mm thick polyethylene sheeting.

Design of solar heating system

The solar energy collecting, storage and distributing system is designed, constructed and installed in the winter season of 1993-1994. The design of the solar energy collector is a surface heating system. It consists of ten parallel water pipes (0.5 inch diameter) which are connected to two header tubes (0.75 inch diameter) as shown in Fig.1. They are painted with matte black paint to absorb the maximum amount of the solar energy flux incident on the upper surface (facing the sun) of each pipe, while the bottom surface of the pipes (facing the inside of greenhouse) is painted with bright white paint to maximize the emissivity and maintain the light level inside the greenhouse at its optimal level. The solar energy collecting system is suspended and fixed on the gable roof of the greenhouse and inclined at 28.8° (as well as the rafter of the greenhouse) from horizontal.

The storage tank is connected to the solar energy collection system by two junctions. One junction is between the bottom of the storage tank and the bottom of the collecting system. The other junction is between the top of the storage tank and the top of the collecting system as shown in Fig. 2. The water is pumped so as to pass through the solar energy collecting system. After the water has passed through the collecting system, it is stored in a 200-liter insulated storage tank (see Fig. 2). The dis-

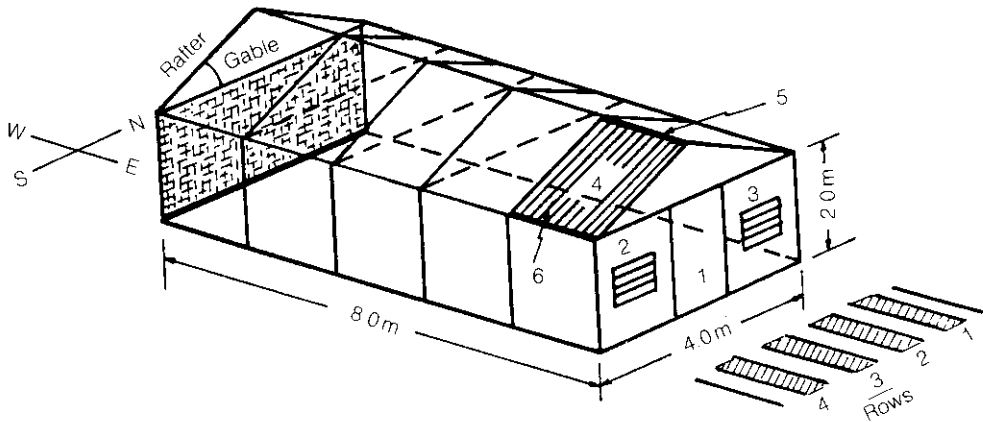

Fig. 1. Schematic diagram of the experimental greenhouse (gable even-span form).
 1) greenhouse door, 2,3) extract fans, 4) solar collector,
 5) header tubes (0.75 inch) 6) water pipes (o.5 inch).

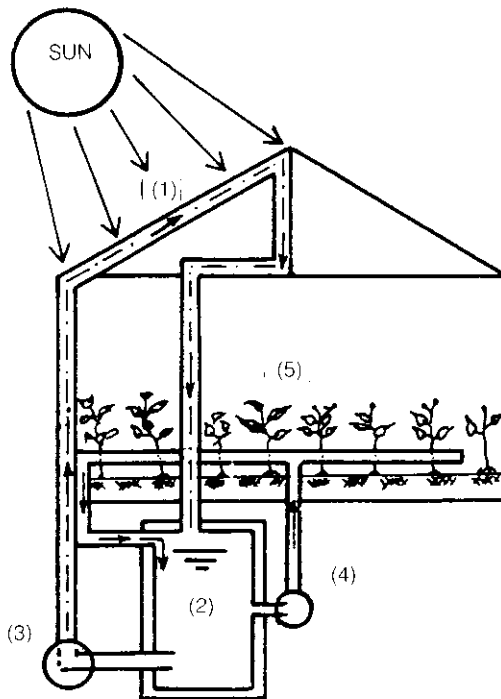

Fig. 2. Diagram showing the arrangement of solar heating system.
 1) solar collector 2) insulated storage tank
 3,4) water pumps 5) tomato plants

tributing system mainly consists of four parallel heat exchangers located inside the greenhouse. They are made from water-galvanized pipes (1.5 inch diameter, in order to increase the area of surface heating) and painted with bright white paint (Fig. 3). The heat exchanger is placed inside the greenhouse on concrete blocks arranged in four rows to be above the floor surface by 25 cm in order to avoid the side effects of wet soil and to be as close as possible to the coldest area of the greenhouse. The heated water from the isolated storage tank is pumped to circulate through the heat exchanger when the ambient air temperature inside the greenhouse is less than 18°C [9] using a differential thermostat (Fig. 3).

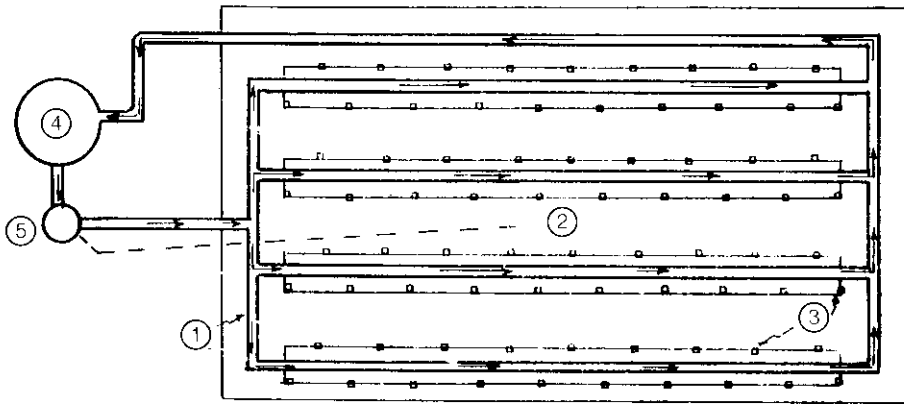

Fig. 3. Diagram showing the arrangement of distribution system.

- | | | |
|-----------------------|----------------------------|------------------|
| 1) heat exchanger | 2) differential thermostat | 3) tomato plants |
| 4) water storage tank | 5) water pump | |

Instrumentation

The ambient air temperatures at various pointed inside the greenhouse are measured using three temperature sensors (thermistors, national semiconductor, LM34). Two thermistors are employed to measure the ground surface (sand ground) temperatures inside and outside the greenhouse. The water temperature in the storage tank was measured using two thermistors. One thermistor is placed outside the greenhouse to measure the exterior ambient air temperature. The temperature of the polyethylene cover is also measured using the other thermistor. Water pipe temperature of the solar collector and heat exchanger are measured using three thermistors. Wet bulb temperatures inside and outside the greenhouse are measured using two thermistors. An anemometer is placed alongside the greenhouse to check excessive air currents over the solar energy systems and the greenhouse. Mass flow rate of water (inside the solar collector) is measured and adjusted using a control valve and

a measuring cylinder with a stopwatch to be 0.5 kg/s. The control valve is mounted in parallel with the pipe between the outlet pipe of the solar collector and storage tank. The measuring cylinder and stopwatch are used to calibrate the flow rate three times per day throughout the experiments to relate between the actual flow rate in litres/minute measured by the measuring cylinder and stopwatch and the valve of 30 litres/minute (0.5 kg/s).

One hundred tomato seeds (RAWA F1, produced late 1992, Holland) are planted in an adapted glasshouse (nursery) on the first of November 1993. The tomato seedlings are raised in 50 mm peat blocks (cylindrical form) and planted out at the four leaves stage. They are located inside the greenhouse in four double rows, each single row having 20 plants. Nitrophoska (18% nitrogen) is used as a ground chemical fertilizer throughout the growing season. Each plant receives 10 grams (one teaspoonful) once every week. Twenty plants are planted outside the greenhouse as a control treatment. Flooding irrigation is employed to irrigate the tomato plants throughout the experimental work.

Mathematical Considerations

The thermal performance of the solar collector system can be described as follows[15]:

$$Q_A = RA_c \tau \alpha \quad (\text{Watt}) \quad (1)$$

where

Q_A = absorbed solar radiation by solar collector.

R = solar radiation available, Watt/m².

A_c = total surface area of solar collecting system, m².

τ = effective transmittance of greenhouse cover to solar radiation

$$\{\tau = 0.90 - 0.00437 \exp [0.0936 (\theta - 30)]\}$$

α = effective absorptance of solar collector pipes to solar radiation

$$\{\alpha = 0.95 - 0.00476 \exp [0.0940 (\theta - 35)]\}.$$

θ = the angle of incidence of solar radiation.

$$Q_{\text{coll}} = mC_p \Delta T, \quad (\text{Watt}) \quad (2)$$

where

Q_{coll} = energy gained in water through the solar collector.

m = mass flow rate of water, Kg/s.

C_p = specific heat of water, J/Kg/K.
 ΔT = change in water temperatures, K.

$$Q_L = Q_A - Q_{\text{coll}} = U_o A_c (T_p - T_o), \quad (\text{Watt}) \quad (3)$$

where

Q_L = heat losses from solar collector.
 U_o = overall heat transfer coefficient, W/M²/K.
 T_p = mean temperature of solar collecting pipes, K.
 T_o = outside air temperature, K.

$$\eta_c = \frac{Q_{\text{coll}}}{RA_c}, \quad (\%) \quad (4)$$

where

η_c = overall thermal efficiency of solar collecting system.

$$Q_s = m_s C_p (T_e - T_b), \quad (\text{Watt}) \quad (5)$$

where

Q_s = energy stored in the storage tank.
 m_s = mass of water in the storage tank, kg.
 T_b, T_e = mean tank temperature at the beginning and at the end of each hour, k.

$$\eta_s = \frac{Q_s}{Q_{\text{coll}}} \times 100, \quad (\%) \quad (6)$$

where; η_s = storage system efficiency.

Heat exchange between the greenhouse and the environment is illustrated in Fig. 4. Heat exchange between the greenhouse interior and exterior is the sum of heat available from all sources (such as solar energy, furnace, lighting, electric motors, etc.) and the rate of heat loss from the greenhouse.

Furnace heat + Electric motor heat + Lighting heat + Solar heat = Heat loss by conduction through the greenhouse shell + Heat loss by air exchange between inside and outside ambient air + Heat loss by evaporating water (7)

Furnance heat is estimated for night heating when there is no sun, and heat from electric motors and lighting is ignored due to its slight effect on energy balance equ-

Cold sky

cold outside air

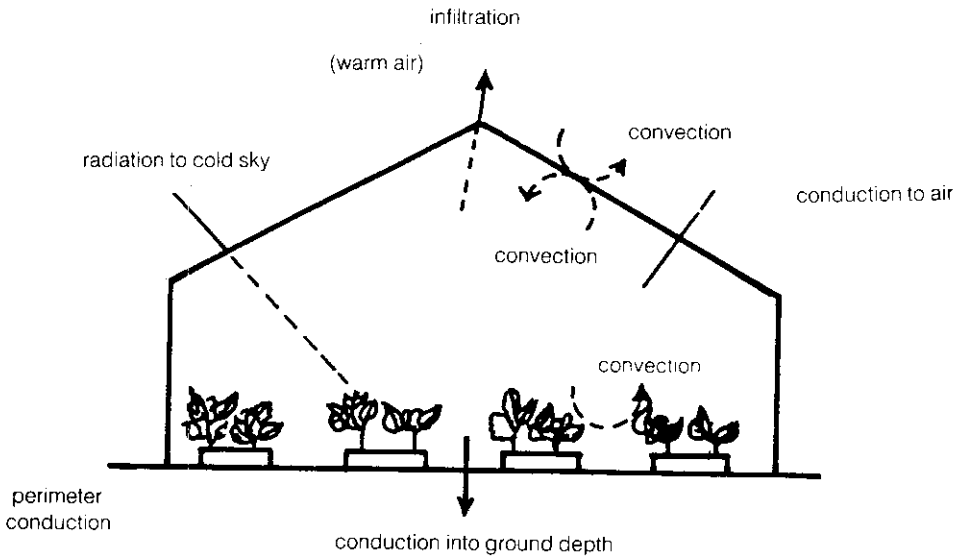

Fig. 4. Heat loss from a greenhouse.

ation. Heat used in evaporating water is also ignored. Therefore, the heating load added to the greenhouse during night time can be calculated by the following equation:

$$\text{Heating load} = Q_{\text{supp}} + Q_{\text{gain}}, \quad (\text{Watt}) \quad (8)$$

$$\text{Heating load} = \text{total heat losses} = Q_c + Q_{\text{mf}}, \quad (\text{Watt}) \quad (9)$$

$$Q_{\text{supp}} = Q_{\text{conv}} = Q_{\text{rad}}, \quad (\text{Watt}) \quad (10)$$

where

Q_{supp} = rate of heat flow supplied from the heating system (furnace).

Q_{conv} = convective heat transfer from distributing system to the interior ambient air.

Q_{rad} = radiation heat transfer from the distributing system to the inside ambient air.

$$Q_{\text{conv}} = A_p h (T_{\text{cp}} - T_{\text{al}}), \quad (\text{Watt}) \quad (11)$$

where

- A_p = total surface area of pipe-heated surface, m^2 .
 h = convective heat transfer coefficient, $W/m^2/K$.
 T_{cp} = temperature of pipe-heated surface, K .
 T_{ai} = interior ambient air temperature, K .

$$Q_{rad} = \epsilon_p A_p \sigma (T_{cp}^4 - T_{ai}^4), \quad (\text{Watt}) \quad (12)$$

where

- ϵ_p = emissivity of the pipe-heated surface, dimensionless.
 σ = Stefan-Boltzmann constant, $5.67 \times 10^{-8} W/m^2/K^4$.

The rate of heat flow (by convection and radiation) transmitted from the sand floor surface area (29.3% of the total floor area) to the interior ambient air and consequently to the greenhouse, Q_{gain} can be computed from the following relationship:

$$Q_{gain} = Q_{conv \rightarrow s} + Q_{rad \rightarrow s}, \quad (\text{Watt}) \quad (13)$$

where

$Q_{conv \rightarrow s}$ = convective heat loss from sand floor surface area (bare area) to the interior ambient air.

$$Q_{conv \rightarrow s} = A_{gi} h_s (T_{gi} - T_{ai}), \quad (\text{Watt}) \quad (14)$$

where

- A_{gi} = surface area of sand floor (bare area), m^2 .
 h_s = convective heat transfer coefficient between sand floor and internal ambient air, $W/m^2/K$.
 T_{gi} = surface temperature of sand floor, K .
 $Q_{rad \rightarrow s}$ = radiation heat loss from floor surface area (bare area) to the interior ambient air.

$$Q_{rad \rightarrow s} = \epsilon_{gi} A_{gi} \sigma (T_{gi}^4 - T_{ai}^4), \quad (\text{Watt}) \quad (15)$$

where; ϵ_{gi} = emissivity of the sand floor surface, dimensionless.

Heat can be lost from the greenhouse in three ways: by convection, radiation and infiltration. Heat is convected directly through the covering material in convection loss. In radiation loss, heat is radiated from warm objects inside the greenhouse through the covering material to colder objects outside. But in infiltration loss, heat

is lost as warm air escapes through damages (cuttings or cracks) in the covering material, as cited by Abdellatif and Lieth [16].

$$Q_{\text{loss}} = Q_c + Q_{\text{inf}} \quad (\text{Watt}) \quad (16)$$

The combination heat losses (by convection and radiation) through the plastic cover of the greenhouse, Q_c and the heat losses due to air infiltration, Q_{inf} , can be calculated from the following equations:

$$Q_c = \sum (U_{\text{og}} A_w) [(T_{\text{ai}} - T_{\text{ab}})], \quad (\text{Watt}) \quad (17)$$

$$Q_{\text{inf}} = m_a C_p_a (T_{\text{ai}} - T_{\text{ao}}), \quad (\text{Watt}) \quad (18)$$

where

- U_{og} = overall heat transfer coefficient of the greenhouse walls, $\text{W}/\text{m}^2/\text{K}$.
- A_w = area of the greenhouse walls, m^2 .
- T_{ao} = exterior ambient air temperature, K .
- m_a = mass flow rate of air, kg/s .

$$m_a = M \times \rho \quad (19)$$

where

- M = greenhouse volume (m^3) \times air exchange rate (1/hr)/3600.
- ρ = density of air, kg/m^3 .

The rate of air exchange between inside and outside is affected by wind, type and quality of greenhouse construction. Reasonable estimates of air exchange rate are given by Aldrich and Bartok [3, p.203]. The rate of air exchange of the greenhouse under specific conditions (new construction, double layer polyethylene film) is one per hour.

The solar gain on sunny days will replace some or all furnace heat (heating load) needed to maintain ambient air temperature at the proper level. When the solar gain exceeds heat loss, the greenhouse air temperature will rise and cooling by ventilation (during winter) or cooling using evaporative cooling system (during summer) may be required. The solar gain (Q_s) can be estimated by:

$$Q_s = I_s \tau A_{gi} \quad (\text{Watt}) \quad (20)$$

where; I_s is the intensity of solar radiation flux incident on the front and back walls of the greenhouse.

The two extract fans which are employed to remove exceeding inside air temperature ($\geq 30^\circ\text{C}$) provided rate of air ventilation determined by the following equation:

$$R_{va} = 2.5 \times L \times W \times F_{house} \quad (\text{m}^3/\text{min}) \quad (21)$$

where

L = greenhouse length, m

W = greenhouse width, m

F_{house} = correction factor of the greenhouse, dimensionless.

Results and Discussion

The thermal performance of the solar energy collection, storage and distribution system is carried out during winter season of 1993- 1994 (167 days are recorded). Data are collected between November 24, 1993 and April 10, 1994. The hourly average solar radiation available inside and outside the greenhouse is illustrated in Fig. 5. For the duration of the experimental work, the daily average solar energy available is 9.618 kWh/day. The absorbed solar energy varies from sunrise to sunset and from one month to another according to the incoming solar radiation. The daily aver-

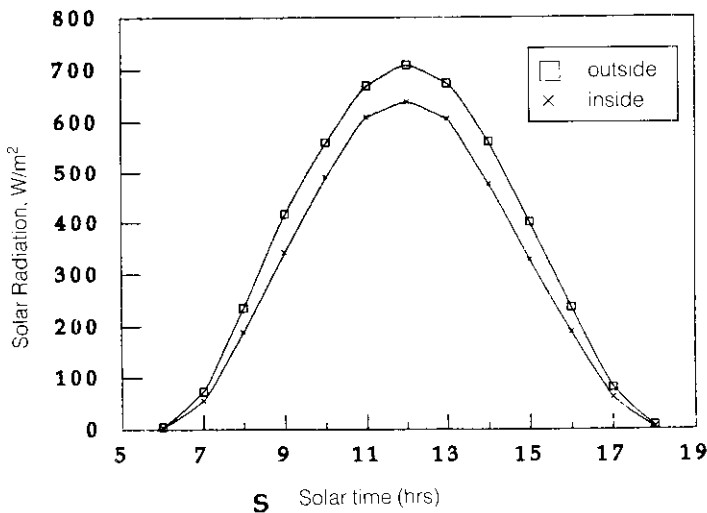
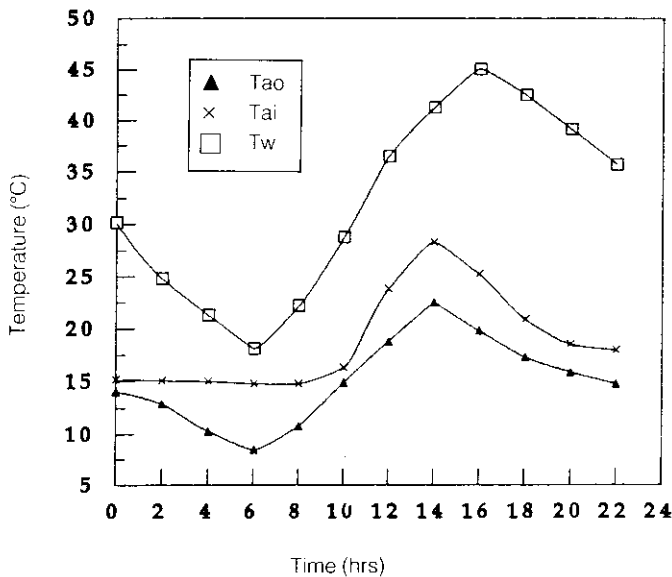

Fig. 5. Hourly average solar radiation available inside and outside the greenhouse.

Table 1. Average daily heat losses, heat gain and heat supplied during the heating season

Month	Q_c (Watt)	Q_{in} (Watt)	Q_{loss} (Watt)	Q_{gain} (Watt)	Q_{supp} (Watt)	Q_{load} (Watt)
November	4765.4	191.5	4956.9	990.5	5323.7	6314.2
December	5286.3	220.5	5506.8	919.7	6062.0	6981.7
January	6375.6	276.0	6651.6	880.1	6686.3	7566.4
February	5807.3	260.8	6068.1	887.4	6793.1	7680.5
March	4860.1	197.5	5057.6	977.3	5570.5	6547.8
April	4385.5	183.9	4569.4	1089.7	6211.2	7300.9
Mean	5246.7	221.7	5468.4	957.5	6107.8	7065.3

**Fig. 6.** Relationship between internal and external ambient air temperatures and water temperature in the storage tank of solar energy system.

The average leaf number of tomato plants throughout the growing season for the four rows of plants is shown in (Fig. 7). The lowest number of leaves is mainly obtained from the first row, which is closest to the northern side of the greenhouse because this row is strongly affected by the cold air surrounding the northern side wall and the cold atmosphere. The previously obtained data may be explained by the

age of absorbed solar energy (7.584 kWh/day) which is converted into useful heat gain to storage during the winter season is 6.265 kWh/day with an average heat transfer efficiency of 82.61%. Mathematical analysis of the measured data reveals that during early morning just after sunrise and just prior to sunset (when the solar radiation at these times is less than 300 Watts and at the same time, the internal ambient air temperature is less than the water temperature in the solar collector), very little useful heat is gained by the water passing through the solar collector. Also, it is noticed that the working fluid (water) dissipates some of its heat energy into the internal ambient air particularly just after sunrise and before sunset.

Thus, the internal ambient air temperature and the wind blowing over the top of greenhouse roof are found to produce a significant negative effect on useful heat collected. Due to the reasons discussed above, the average daily solar collector heat losses of a daily average are 1.319 kWh/day. Also, and for the same reasons, the overall thermal efficiency of the surface heating system is 65.14%. The average daily stored energy in the storage tank during this experiment is 5.435 kWh/day, which gives an average storage system efficiency of 86.75%. Consequently, 13.25% of useful heat gain to storage is lost during the heating season. The storage tank is located outside the greenhouse; and is thus exposed to wind blowing over the system and the low temperature of ambient air. Further experiments will be employed to compare the difference between the storage tank located inside and outside the greenhouse. By locating the storage tank outside less energy is stored than if it is located inside. However, by locating it outside more area is available within the greenhouse as a planting area, furthermore, the storage tank will not shade part of the planting area.

The effectiveness of the distribution system (pipe coil) varies from time to time and from one day to another according to the water temperature in the storage tank of the solar energy system and the temperature difference between the internal and external ambient air of the greenhouse. The heat losses from the greenhouse (convection, radiation and infiltration), heat gain from the ground surface, and heat supplied from the surface heating system are summarized in Table 1. These show great variation on a daily and monthly basis due to the variation in temperature difference between internal and external air temperatures (Fig. 6). Thus, the greatest value of heat losses occurs in January (when the average daily of external air temperature during night is 8.5°C). The stored solar energy actually utilized in the heating operation is 5.532 kWh/day; so that 88.3% of the solar energy stored in the storage tank is employed. The main parameters affecting the proportion of energy consumed to heat the greenhouse are: the solar collector surface area, the external ambient air temperature, and the stored solar energy.

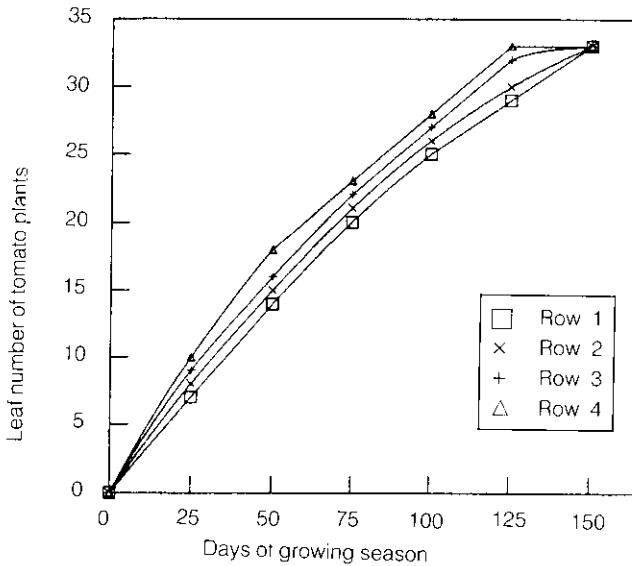

Fig. 7. Average tomato leaf number for the four rows.

fact that all biochemical reactions in the plant are mainly controlled by enzymes (enzymes are heat sensitive). Numerous biochemical reactions are involved in the process of photosynthesis - all having the net effect of building carbohydrates and storing energy. Photosynthesis occurs during the day light hours because of its dependence on light. Therefore, the fourth row which is continuously exposed to the greatest amount of light intensity has the greatest number of leaves. In spite of these variations in leaf number between the four rows, the average number of leaves (22 leaves) may be considered as the best number which can be achieved from greenhouse tomato production during the winter season.

Figure 8 illustrates the average height of tomato plants at certain days of the growing season for the four rows. It clearly shows that the greatest height of tomato plants is achieved from row 4. This achievement usually occurs throughout the experiment due to the great number of leaves - the leaf being the main source of energy for the process of photosynthesis and consequently the building of carbohydrates. As the green areas of leaves are increased (due to increase of leaf number), the biochemical processes are increased making the process of photosynthesis more efficient. Thus, the rate of growth is high and remains the same throughout the growing season.

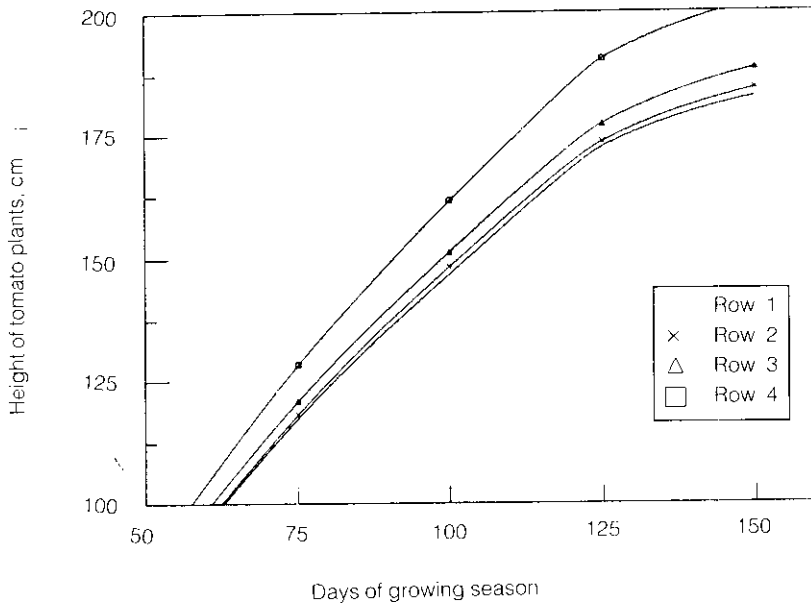

Fig. 8. Average height of tomato plants for four rows.

The average fresh tomato yield for the four rows during this experiment is shown in (Fig. 9). It clearly shows that the utilization of new aspects in greenhouse tomato production (which are employed in this experimental work) achieves better results in comparison with the tomato plants outside the greenhouse and compared to the production of the commercial greenhouse at the same research station (average fresh yield = 1.50 kg/plant), while the average fresh tomato yield obtained from this experiment is 2.20 kg/plant. Consequently, this new greenhouse is found to give an average of 46.67% greater production than commercial greenhouses.

Conclusions

The solar energy collection (surface heating) as well as the storage and distribution system (heat exchanger) operate satisfactorily throughout the experimental work. Ultimately the methods of greenhouse tomato production employed in this research work enhance the rate of growth and increase the fresh tomato yield by 46.67% in comparison with the commercial greenhouse at the same research station.

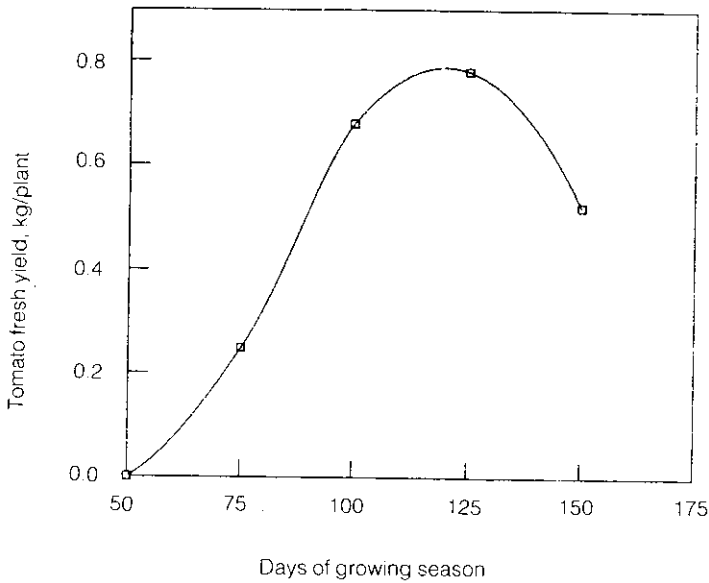

Fig. 9. The mean value of tomatoes fresh yield.

References

- [1] Abdellatif, S.M. "New Aspects in Greenhouse Cucumber Production under Hot and Humid Climate." *Mansoura University, J. of Agricultural Sciences*, 18, No. 8 (1993), 2397-2412.
- [2] Kimball, B.A. "A Modular Energy Balance Program including Subroutines for Greenhouses and other Latent Heat Devices." *USDA-ARS Publication, ARS-33* (1990).
- [3] Aldrich, R.A. and Bartok, J.W. *Greenhouse Engineering*. New York: Ithaca, 1989.
- [4] Mishoe, J.W., Jones, J.W., Swaney, D.P., and Wilkerson, G.G. "Using Crop and Pest Models for Management Applications." *Ag. System* 15 (1984), 153-170.
- [5] Boote, K.J. and Jones, J. "Applications of, and Limitations to, Crop Growth Simulation Models to Fit Crops and Cropping Systems to Semi-arid Environments." *ICRISAT, India* (1986).
- [6] Schapendonk, A.H.M.C. and Gaastra, P. "A Simulation Study on CO₂ Concentration in Protected Cultivation." *Sci. Hort.* 23 (1984), 217-229.
- [7] Hwang, Y. *An Engineering Economic Analysis of Night-time Temperature Control Systems for Florida Greenhouses*. M.Sc. Thesis, University of Florida, Gainesville, (1989).
- [8] Challa, P.W., Baker, J.C., Bot, G.P.A., Udink Ten Cate, and Van DE Vooren, J. "Economical Optimization of Energy Consumption in an Early Cucumber Crop." *Acta Hort.*, 118 (1981), 191-200.
- [9] March, L.S., Albright, L.D., Langhans, R.W., and McCulloch, C.E. "Economically Optimum Day Temperatures for Greenhouse Hydroponics Lettuce Production." *ASAE Paper No. 874023*, (1987).
- [10] Bakker, J.C. "A CO₂ Control Algorithm Based on Simulated Photosynthesis and Ventilation Rate." *Acta Hort.*, 174 (1985), 387-392.
- [11] Jones, P, Jones, J.W., Allen, L.H., and Mishoe, J.W. "Dynamic Computer Control of Closed Environmental Plant Growth Chambers, Design and Verification." *Transactions of the ASAE*, 27, No. 3 (1984), 879-888.

- [12] Jones, P., Jacobson, B.K., Jones, J.W., and Paramore, J.A. "Real-time Greenhouse Monitoring and Control with an Expert System." *ASAE*, Paper No. 864515, (1986).
- [13] Jones, P., Jones, J.W., Dayan, E., Hwang, Y., and Jacobson, B. "Modeling Tomato Growth for Greenhouse Environment Control." *ASAE*, Paper No. 887501, (1988).
- [14] Jones, P., Jones, J.W., and Hwang, Y. "Simulation for Determining Greenhouse Temperature Set Points." *Transaction of the ASAE*, 33, No. 5 (1990), 1722-1727.
- [15] Rumsey, T.R. and Fortis, T. "Long Term Performance of Solar Air Heaters." *ASAE*, Paper No. 824037, (1982).
- [16] Abdellatif, S.M., and Lieth, H.J. "Heat Requirements for Maintaining Optimum Ambient Air Temperature of Glass Houses." *Misr J. of Agricultural Engineering*, 9, No. 4 (1992), 635-655.

استغلال الطاقة الشمسية في إنتاج محصول طماطم البيوت المحمية

علي مفرح العمري

قسم الهندسة الزراعية، كلية العلوم الزراعية، والأغذية، جامعة الملك فيصل

ص.ب ٤٤٢١ الأحساء ٣١٩٨٢، المملكة العربية السعودية

(قدم للنشر في ١٤١٥/٧/٢٩هـ؛ وقيل للنشر في ١٤١٦/٦/٢٢هـ)

ملخص البحث. يهدف هذا البحث التجريبي إلى دراسة إمكانية استغلال أجهزة الطاقة الشمسية في تسخين الهواء المحيط داخل البيت المحمي الجمالوني الشكل، بحيث تم استغلال أقطاب من سقف البيت المحمي المائل والمتجه جهة الجنوب كسخان شمسي لتوفير المياه الساخنة اللازمة لعملية التدفئة أثناء الليل وذلك للمحافظة على درجة حرارة الهواء داخل البيت المحمي عند ١٨°م. وقد تم استخدام برنامج رياضي لحساب كمية الأشعة الشمسية الساقطة على سطح البيت المحمي، وتم كذلك قياس واختبار وحساب الأداء الحراري لنظام التدفئة باستخدام العديد من المعادلات ذات العلاقة. وقد أوضحت نتائج العمل التجريبي أن طريقة تدفئة البيت المحمي بالطاقة الشمسية والمخصصة لإنتاج محصول الطماطم قد شجّع على زيادة معدل النمو وزيادة الإنتاج من الطماطم الطازجة بمعدل ٦٧، ٤٦٪ لمحصول الشتاء بالمقارنة مع البيوت المحمية التجارية (البيوت المحمية الكبيرة الحجم) بالمحطة نفسها.

لذا فإنه يمكن استخدام جزء من سقف البيت المحمي كسخان شمسي ذاتي تحدد مساحته على حسب مساحة الأرض تحت البيت المحمي وكمية الطاقة الشمسية المتاحة في المنطقة والفرق في درجة الحرارة بين هواء البيت المحمي والهواء الخارجي.