

Water Supply Network System Control Based on Model Predictive Control

Adel Abdulrahman* and Nagib Nasher**

* Mechanical Engineering Department,
Faculty of Engineering, Sana'a University,
ahzaa@suye.ac

** Civil Engineering Department,
Faculty of Engineering,
University of Science and Technology

(Received 21/6/2008; accepted for publication 18/7/2009)

Keywords: Water supply system, Model predictive control, Constraints.

Abstract. An increasing demand for water due to population growth, industrial development and improvement of economic require management of water transfer and improved operation of water supply systems. This paper considers the application of a controller that is approved to be robust to improve the behavior of the water network supply system, to maintain stable operation of the water flow rate, and reduce the operational cost by manipulating the pump speed. The model predictive control (MPC) algorithm is one of the most common automatic control system that has got a wide spread application in process industry. The results show that the MPC technique gives improved performance over the PID control technique. Moreover, the MPC structure can be modified to handle the constraints applied on the system.

Introduction

Global demand for water is continuously increasing due to population growth, industrial development, and improvements of economic conditions, while accessible sources keep decreasing in number and capacity. Moreover, the applications involving manipulation and transport of water and fluids in general demand high power consumption. The optimal use of such water supply networks seems to be the best solution for the present, and thus it is necessary to carefully manage water transfer (Biscos *et al.*, 2003; Eker and Kara, 2003).

Most of the research in the field of water distribution has been concerned with the optimal design of new networks (Mousavi and Ramamurthy 2000; Cunha and Sousa, 1999; Joitt and Gerrmanopoulos. 1992; Creasey, 1982). The main topic of this research has been mainly focused on the design of optimized configurations for pipe interconnected reservoirs (Mousavi and Ramamurthy, 2000) or concentrated on the scheduling of pumps (Cunha and Sousa, 1999; Joitt and Gerrmanopoulos, 1992). However, the energetic efficiency will be sacrificed when the pumps operate

under a variable load and hence under non-optimized conditions. The optimized operation of this kind of system usually results in a control strategy determination problem for the active elements for measuring the monitoring variable so that some performance target is reached (power minimization, pressure limitation to avoid leakage, etc.). A few researchers have developed techniques for the operational optimization of existing supply networks (Biscos *et al.*, 2003; Eker and Kara, 2003; Cembrano *et al.*, 2000). The objective of this research is the contribution in controlling a water supply network system using powerful control algorithm such as the model predictive control (MPC) algorithm. The model predictive control algorithm is an alternative to the conventional PID (proportional-integral-derivative) controller, which is based on correcting the error between a measured process variable and a desired set-point by calculating and then outputting a corrective action that can adjust the process accordingly and rapidly, to keep the error minimal, and other advance control algorithm such as the H_{∞} control algorithm used by Eker and Kara (2003) for its superiority and robustness.

The idea of the MPC emerged in 1965, where Dawkins and Briggs in 1965 used weighting function as a system description for use in optimal control. However, it was rarely used as a controller in control engineering until the advent of digital computers. There are different MPC algorithms that could be suitable for single and multivariable systems and are successfully applied to real life processes including dynamic matrix control (DMC) developed by Cutler and Ramaker in 1978, and generalized predictive control (GPC) (Clarke and Mohtadi, 1987). More review on these algorithms is given by Mackay *et al.* (1994). All of these classes of MPC have certain features in common, implementation of receding horizon to solve a finite horizon optimization problem, with differences occurring in the sequence of control implementation and in the underlying formulation of the models and constraints. Some of these MPC methods use non-parametric weighting function models forms during the prediction process, and others use parametric models. Parametric predictive controllers allowed for a more efficient algorithm and making the incorporation of adaptive techniques more feasible, whereas non-parametric predictive controllers are very robust when compared to parametric models, at the cost of computation power. DMC uses non-parametric step response models to generate both the free and forced responses. However, GPC uses the impulse response to generate the forced response, parametric controlled auto-regressive and integrated moving average (CARIMA) model to generate the free response. A different number of extensions to the original DMC have been incorporated to deal with constraints, multi-variable interactions and nonlinear systems (Shridhar and Cooper, 1997; Gupta, 1998; Mackay *et al.*, 1994, 1996; Ali and Zafirio, 1993; Abdulrahman *et al.*, 2002), and a review on the recent advances on MPC algorithm is given by Henson (1998). The idea of the predictive control structure is based on a very natural manner of interpreting feedback control, as illustrated in Fig. 1, where the process model is in parallel to the plant. It can be said that the MPC scheme is based on the explicit use of a process model and process measurements to generate values for process input as a solution of an online (real-time) optimization problem to predict the future process behavior. The process measurements provide the feedback (and optionally, feed-forward) element in the MPC structure.

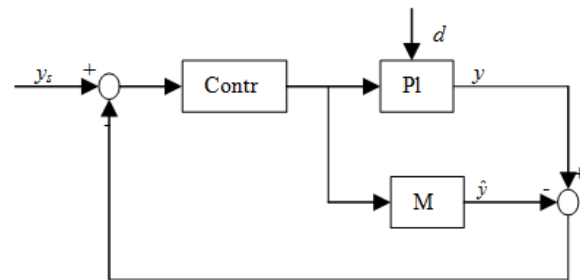

Fig. 1. Predictive control structure.

The MPC structure can be summarized by the following steps:

- At each control interval t , the process output response is predicted p -steps ahead into the future $y(t+l)$, where $l = 1, \dots, p$. The prediction value $y(t+l)$ depends on the past actuation and the planned m -step ahead actuation $\{\Delta u(t+j), j = 1, \dots, m-1, m < p\}$.
- The planned moves $\{\Delta u(t+j), j=1, \dots, m-1\}$ are calculated from minimizing a quadratic cost function. The cost function index incorporates the errors (the difference between the future reference trajectory and the predicted process output) and actuation moves. Although the vector of future control moves is calculated, only $u(t)$ is applied to the process.
- The prediction is corrected at each stage by comparing the current measured values and its predicted values through a filter.

The above steps are repeated at each control interval, and this is referred to as receding horizon strategy as shown in Fig. 2.

From the viewpoint of practical industrial applications, the method has some important advantages over other control techniques:

- Applicable to processes with unusual and difficult dynamic behavior.
- Can handle in a straightforward way multivariable interactive control problems.
- Has inherent dead-time compensation.
- Introduces feed-forward control in a natural way (for compensating measured disturbances).
- Conceptually simple to extend to constrained control problems.
- Intuitive in nature and robust in approach.

The general mathematical formulation for the DMC algorithm as a MPC structure mentioned above is composed of two distinct steps:

1. The output prediction must be constructed based on the model and other information available, such as plant measurements.

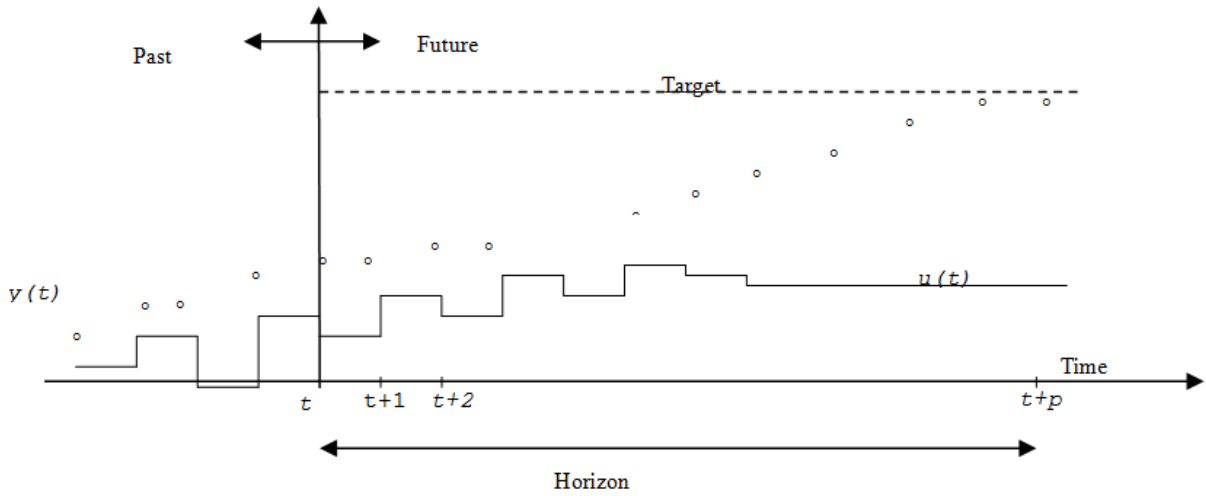

Fig. 2. The receding horizon strategy.

2. Having the prediction output, a set of future manipulated variable moves must be computed.
At the beginning, at $t = 0$, the process should be at steady state. The current state for the model and the plant should be the same as the measured value of the plant, increment the discrete time variable t and;
1. Predict the output model using the value of the actuation to the model prediction the same as the actual value implemented on the plant

$$\hat{Y}(t+1/t) = M_{shift} \hat{Y}(t/t) + S^u \Delta U(t) \quad (1)$$

where

M_{shift} is the shift matrix for the output to include the predicted information and keep the prediction horizon vector constant. The last value is simply repeated, as p is assumed to equal the settling time n of the plant response; S^u is the step response coefficient and $\Delta U(t-1) = [\Delta u(t-1) \Delta u(t) \Delta u(t+1) \dots \Delta u(t+m-1)]^T$. Where, m is the number of allowable moves to be computed over the horizon p . The control horizon m should be less than or equal to the prediction horizon p . If $m < p$, then the step response matrix S^u is of reduced order. This has the effect of reducing the computational time and increasing the robustness of the controller in the presence of plant and model mismatch.

2. The predicted output in Eq. 1 is corrected by the plant prediction error, which could be the result of instrument/process noise, process disturbance or modeling errors, and then the corrected prediction output becomes;

$$\hat{Y}(t+1/t) = M_{shift} \hat{Y}(t+1/t) + k_f (y_{meas}(t) - \hat{y}(t+1/t)) \quad (2)$$

where, k_f is the filter that eliminates high frequencies in the feedback loop. The inclusion of the filter term in any instance would preserve the dynamics of the system, by removing the assumption that the error of the current sample would be consistent for future samples. In this work, the filter term is not taken into account and is assumed to be 1.

3. Compute the future changes in input that minimize the errors between the actual output response and the desired output response, with the addition of penalizing the movement of the actuation for smoother control, the following optimizing quadratic cost function is used.

$$J = (I^y E^u(t+1/t))^T (I^y E^u(t+1/t) + (I^u \Delta U(t))^T (I^u \Delta U(t)) \quad (3)$$

where, I^y is the diagonal output weight matrix consisting of γ^y , and I^u is the diagonal output weight matrix consisting of γ^u , $E^u(t+1/t)$ is the future predicted error;

$$E^u(t+1/t) = R(t+1) - M_{shift} \hat{Y}(t+1/t) - S^u \Delta U(t) \quad (4)$$

$R(t+1) = [r(t+1) \ r(t+2) \ \dots \ r(t+p)]$ is the reference trajectory. To find the optimum input vector $\Delta U(t)$ over the control horizon, the cost function J should be minimized with respect to $\Delta U(t)$. By differentiating the cost function J Eq. 3 with respect to $\Delta U(t)$ and equating the result to zero, this will give us the optimum control vector:

$$\Delta U(t) = K_{MPC} E^o(t+1/t) \quad (5)$$

$E^o(t+1/t)$, the error trajectory with no future control action ($\Delta U(t) = 0$) is given by

$$E^o(t+1/t) = R(t+1) - M_{shift} \hat{Y}(t+1/t) \quad (6)$$

The constant gain matrix K_{MPC} can be calculated off-line as

$$K_{MPC} = (S^u T \Gamma^y T \Gamma^y S^u + \Gamma^u T \Gamma^u)^{-1} S^u T \Gamma^y T \Gamma^y \quad (7)$$

An important characteristic of control problems is the presence of constraints on input and output variables. Input and output constraints are usually associated with operational limitations. The presence of such constraints results in online optimization that produces a nonlinear controller, even when the plant and model dynamics are assumed linear. It is important to note that the input constraints are hard constraints, in the sense that they must be satisfied; output constraints can be viewed as soft constraints because their violation may be necessary to obtain a feasible optimization problem. For the model predictive control to deal with constraints the quadratic cost function (Eq. 3) should be formulated in a way that can be solved by the quadratic programming (QP) method. A standard QP problem can be stated as follows:

$$\min_x f = \frac{1}{2} x^T H x - g^T x \quad (8)$$

Subjecto $Ax \leq b$

where, H is the Hessian matrix, g is the gradient vector, A is the inequality constraint equation matrix, and b is the inequality constraint equation vector. By substituting and expansion of Eq. 3, the cost function can be reduced in form of

$$J = \frac{1}{2} \Delta U^T(t) \left[S^u T \Gamma^y T \Gamma^y S^u + \Gamma^u T \Gamma^u \right] \Delta U(t) - \left[S^u T \Gamma^y T \Gamma^y E^o(t+1/t) \right] \Delta U(t) \quad (9)$$

which, is in the same form as the QP problem, where,

$$H = S^u T \Gamma^y T \Gamma^y S^u + \Gamma^u T \Gamma^u \text{ and}$$

$g = S^u T \Gamma^y T \Gamma^y E^o(t+1/t)$. It can be noticed that the Hessian matrix H is constant and it can be calculated offline, and that the gradient vector g is a function of

the error trajectory $E^o(t+1/t)$, which is updated at each control interval. The cost function (Eq. 9) is subjected to constraints

$$A \Delta U(t) \leq b \quad (10)$$

where A is the inequality constraint matrix, $A = [I_1 - I_1 I - I S^u - S^u]^T$, I_1 is an $(m \times m)$ lower triangular matrix, I is an $(m \times m)$ identity matrix, b is the inequality constraint vector; $b = [u_{high}(t) - u(t-1), \dots, u_{high}(t+m-1) - u(t-1), u(t-1) - u_{low}(t), \dots, u(t-1) - u_{low}(t+m-1), \Delta u_{max}(t) \dots \Delta u_{max}(t+m-1), \Delta u_{max}(t) \dots \Delta u_{max}(t+m-1), -M_{shift} \hat{Y}(t/t) + y_{high}(t+1), M_{shift} \hat{Y}(t/t) - y_{low}(t+1)]^T$.

Now the MPC problem is a minimization of a quadratic cost function over the decision vector $\Delta U(t)$, subject to the linear inequality equations. This encompasses both requirements for the constraint variables to lie in the feasible region, and for $\Delta U(t)$ to minimize the quadratic cost function. As the number of constraint increase, the number of QP increases and may exceed the maximum time allowed to complete the calculation within the control interval. In the moving horizon strategy, the QP algorithm is solved at each control interval after a new prediction vector becomes available. For the QP in MPC, the Hessian matrix H is constant, but the gradient vector g and vector b need to be updated at each control interval because of the generation of a new error vector at each control interval. A number of numerical iterative techniques exist to solve the resulting QP problem. The method which is used for solving this QP problem is the active set method (projection method) supported in the MatLab software package due to its fast convergence.

Water Supply Systems

Water supply systems are generally composed of a large number of interconnected pipes, reservoirs, pumps, valves, and other hydraulic elements which carry water from retention to demand areas (Biscos *et al.*, 2003; Eker and Kara, 2003; Cembrano *et al.*, 2000). The hydraulic elements in a supply system may be classified into two categories: active and passive. The active elements are those which can be operated to alter the flow rate of water in specific parts of the system, such as pumps and valves. The pipes and reservoirs are passive elements, insofar as they receive the effects of the active elements. These elements in the supply systems play important roles in dynamic behavior of the water supply systems. Simulations of the water supply systems have been an indispensable work to understand their behavior to produce a feasible

control solution as well as modeling. The simulations can thus be used to generate ideas in order to develop flexible management and design schemes. Consequently, this process may facilitate a better exchange of ideas among representatives of different professions. It also combines technical and financial viewpoints. The first step in simulation and control is to establish a mathematical model for the plant to be controlled. Furthermore, an adequate model is an important step in determining the behavior of the system and producing well tuning parameters of the PID control algorithm.

Hydraulic systems generally require complex models. Derivation of control strategies on the basis of the complex models is difficult. For these reasons, the plant model should be chosen to be simple with a minimum number of dominant variables, which, nevertheless, adequately reflect the dynamics of the plant. The plant can be described by the parameters that characterize its functioning such as the pumps discharges, water heads in the reservoirs, and flow rates through the system. Thus, the simulation of the model that represents a water supply system may prove an efficient measure to contribute to the correct transfer of water and to reduce operational cost, as well as to improve the operation. The active and passive elements are represented by dominant system variables. The main objectives are to ensure the proper operation of a water supply system and to regulate the water flow rates and heads by manipulating the water pumps. By assuming that the water is incompressible and the individual system components are stationary the hydraulic model of the supply system is composed of the following models for every component of the supply system.

Pumps

Head developed by n variable-speed pumps running in parallel varies nonlinearly with their speed N and output water flow rate $Q_p(t)$

$$H = A_o + B_o \sqrt{Q_p} + C_o N^2 \quad (11)$$

where A_o , B_o and C_o are the constants for a particular pump depending on component characteristics (Eker and Kara, 2003). These constants can also be calculated using appropriate manufacturer's specifications.

Pipes

Consider a pipe section with length l_p and cross-sectional area A_p . If the head difference Δh between

two ends of the pipe section is considered, the following differential equation is obtained:

$$\frac{dQ}{dt} + \frac{g}{l_p} \int_0^{l_p} Q dt = \frac{g}{l_p} \Delta h \quad (12)$$

where $h_{loss}(t)$ denotes the total head loss along the piping section and g denotes the acceleration of gravity. The flow rate and head loss may be given as:

$$h_{loss} = h_{loss}^o + \Delta h_{loss} \quad (13)$$

where $(.)^o$ denotes steady-state value and $\Delta h_{loss}(t)$ designates the variable head loss caused by the variable water flow rate $\Delta Q(t)$.

Water reservoir

When a reservoir discharges under its own head without external pressure, the continuity equation simplifies to:

$$\rho_i Q_i - \rho_o Q_o = \rho \frac{dh}{dt} \quad (14)$$

where ρ , ρ_i and ρ_o represent the water densities inside the reservoir, water inflow, and outflow, respectively, and assuming $\rho = \rho_i = \rho_o$. $Q_i(t)$ and $Q_o(t)$ denote reservoir input and output water flow rates, respectively, c denotes the capacity of the reservoir and $h(t)$ is the head in the reservoir.

A single input single output linear model of a water supply system considered in our study has been developed for the Gaziantep water supply system shown in Fig. 3 by Eker and Kara (2003).

The input to the system is considered to be the pump speed N rpm and the output of the system is the flow rate from the third reservoir $Q_o(t)$. The numerical data about the water supply system are given in Table 1. The output water flow rate was measured at $1-h$ intervals in a day, so 24 measurements were taken using a flow meter installed on the real system.

Table 1. Numerical data of the water supply system

$l_1 = 669.27 \text{ m}$	$A_p = 1.5394 \text{ m}^2$	$D = 1.4 \text{ m}$	$l_2 = 13805.04 \text{ m}$	$h_{i1} = 113.4 \text{ m}$
$g = 9.81 \text{ m/s}^2$	$l_3 = 20094.69 \text{ m}$	$h_{i2} = 210.4 \text{ m}$	$l_4 = 4689.04 \text{ m}$	$h_{i3} = 283.4 \text{ m}$
$N_{so} = 985 \text{ rpm}$	$A_i = 475 \text{ m}^2$	$h_{sd} = 2.79.7 \text{ m}$	$Q_{so} = 2.83 \text{ m}^3/\text{s}$	

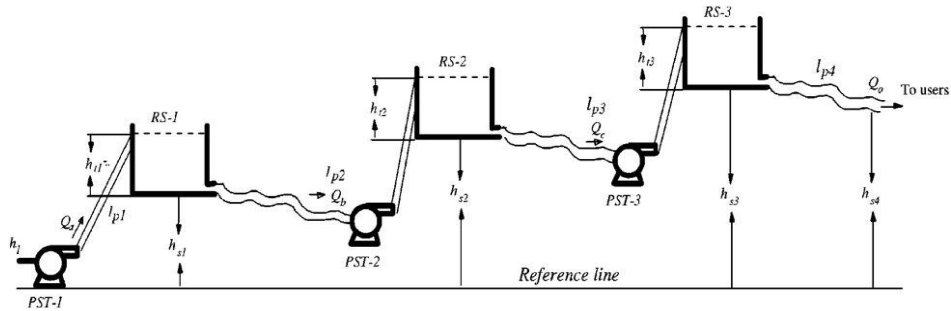

Fig. 3. Diagram of the water supply system taken from Eker and Kara (2003).

Using the data obtained, the average water flow rate is about $Q_o = 2.83$ ($10190 \text{ m}^3/h$) and it changes between $10175 \text{ m}^3/h$ and $10200 \text{ m}^3/h$. The pump characteristics were obtained from the pump's manufacturer. Head developed by the pump was calculated around the operating point using the characteristic curve as

$$h_p(N, Q_p) = 0.0001433N^2 + 0.00501NQ_p - 3.98Q_p^2 \quad (15)$$

The linear model of the water supply system shown in Fig. 1 was obtained by linearizing the mentioned system using the Taylor series expansion method around a steady-state operating point ($N_{so} = 985 \text{ rpm}$, $Q_{so} = 2.83 \text{ m}^3/s$).

A detailed study on the system modeling is given by Eker and Kara (2003). The resulting Eqs. (16-23) of the system using the above data and operating point are as follows:

$$\frac{dQ_1}{dt} = \dots \quad (16)$$

$$\frac{dh_1}{dt} = \dots \quad (17)$$

$$\frac{dQ_2}{dt} = \dots \quad (18)$$

$$\frac{dh_2}{dt} = \dots \quad (19)$$

$$\frac{dQ_3}{dt} = \dots \quad (20)$$

$$\frac{dh_3}{dt} = \dots \quad (21)$$

$$\frac{dQ_4}{dt} = \dots \quad (22)$$

$$y = Q_o \quad (23)$$

This system can be represented in state space matrix form such that the reservoir heads and flow rates can be considered as states. The canonical state space form of the above Eqs. (16-23) (Eker and Kara 2003) is as follows:

$$\begin{cases} \dot{x} = Ax + Bu \\ y = Cx \end{cases} \quad (24)$$

where $x(t)$ is the state matrix, A , B and C are the constant system matrices, $u(t)$ is the system input, and $y(t)$ is the system output. The state matrix $x(t)$, input $u(t)$, and calculated constant matrices A , B and C are as follows:

$$x(t) = [Q_o \ h_3 \ Q_3 \ h_2 \ Q_2 \ h_1 \ Q_1]^T, \ u(t) = N, \\ B = [0 \ 0 \ 0 \ 0 \ 0 \ 0 \ 0.0067]^T, \ C = [1 \ 0 \ 0 \ 0 \ 0 \ 0 \ 0], \text{ and}$$

$$A = \begin{bmatrix} -0.0001 & 0.0002 & 0 & 0 & 0 & 0 & 0 \\ 0.0001 & 0 & 0.0001 & 0 & 0 & 0 & 0 \\ 0 & -0.0008 & -0.0008 & 0.0008 & 0 & 0 & 0 \\ 0 & 0 & -0.0001 & 0 & 0.0001 & 0 & 0 \\ 0 & 0 & 0 & -0.0011 & -0.0015 & 0.0011 & 0 \\ 0 & 0 & 0 & 0 & -0.0001 & 0 & 0.0001 \\ 0 & 0 & 0 & 0 & 0 & -0.0005 & -0.0005 \end{bmatrix}$$

The response of the open loop system without compensation to $\pm 10\%$ step response from the nominal value of 985 rpm is shown in Fig. 4.

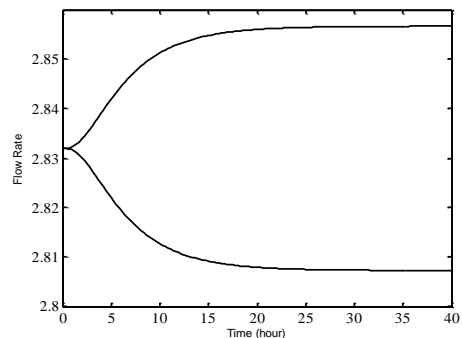

Fig. 4. Output flow rate $Q_o(t) \text{ m}^3/s$ for $N = 985 \pm 10\%$ rpm square wave speed variation.

Control of the Supply System Using MPC Algorithm

The proposed MPC algorithm is applied to control the water supply network system to provide stable operation, improve performance costs, and reduce the cost of operation and save electricity in the event of having many pumps operating simultaneously, by manipulating the speed of one of the pumps and letting the rest to operate at the minimal speed. For the closed-loop simulation, the control algorithm was set up with the linearized model described earlier in Eq. (24), and step response of the model is obtained. The new set points were introduced. The tuning parameters were chosen so that the integrated square error (ISE) between the simulated output and set point is minimized, as follows: $p = 25$, $m = 2$, $I^m = 0.95$ and $I^y = 1$. The pump operation was constrained between a maximum value of 1000 rpm and a minimum value of 700 rpm. The tuning parameters of the PID controller were obtained using Ziegler-Nichols method as $K_p = 271.215$, $K_i = 13217.11$, and $K_d = 3132.11$.

Figures 5 and 6 illustrate the closed-loop response of the output flow rate of the system to a desired steady state values. It can be noticed that all the controllers takes the system response to the new values, but their performance are comparable. However, the rising time of the closed-loop response is faster in the case of unconstrained MPC comparing to the constrained MPC and PID controller. The constrained MPC has a good settling time slower than the settling time for non-constrained MPC and faster than the settling time for the PID controller. Moreover, the constraints are kept within their interval which makes MPC a successful control technique for controlling this water supply network system. In general, it can be said that the MPC algorithm adapts quickly to the changing conditions of the water supply network system. The MPC structure can be modified to meet possible requirements concerning energy consumption and to handle the constraints applied to the system.

Conclusion

It is clear that the robust MPC technique with a moving optimization horizon offers an effective means of dealing with the problem of water transfer operation to achieve goals such as flow rate regulation and cost minimization. This concept has the intrinsic ability to compensate for changes in water disturbance that may occur at any point of the water supply system.

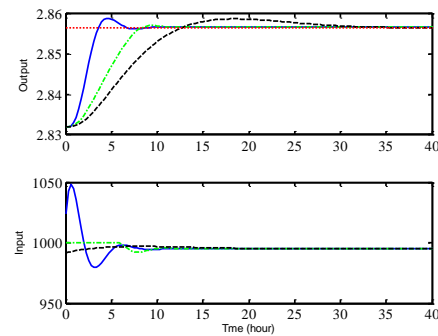

Fig. 5. Closed-loop system response to a desired steady state output flow rate of $2.86 \text{ m}^3/\text{s}$ due to the effect of non-constrained MPC (solid), constrained MPC dash-dotted and PID controller (dashed).

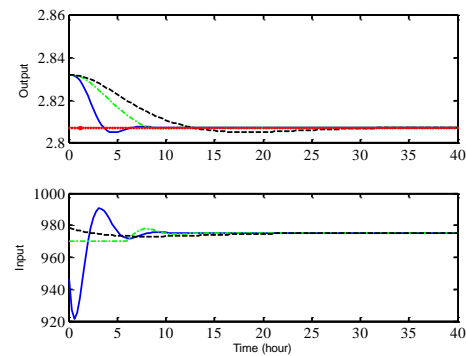

Fig. 6. Closed-loop system response to a desired steady state output flow rate of $2.81 \text{ m}^3/\text{s}$ due to the effect of non-constrained MPC (solid), constrained MPC dash-dotted and PID controller (dashed).

References

- Abdulrahman, A.; Soufian, M.; Mokbel, A. and Soufian, M. "Neural Network for Model Based Predictive Control of a Polymerization Reactor." *Proceedings of the 4th International Conference on Recent Advances in Soft Computing (RASC 2002)*, Nottingham, U.K., (December 2002), 13-19, 12-13.
- Ali, E. and Zafiriou, E. "Optimization-based Tuning of Nonlinear Model Predictive Control with State Estimation." *Journal of Process Control*, Vol. 3, No. (2), (1993), 97-107.
- Biscos, C.; Mulholland, M.; Lann, M-V. Le; Buckley, C. A. and Brouckaert, C. J. "Optimal Operation of Water Distribution Networks by Predictive Control Using MINLP." *Water S. A.*, Vol. 29, No. (4), (2003), 393-404.
- Cembrano, G.; Wells, G.; Quevedo, J.; Perez, R. and Argelaguet, R. "Optimal Control of a Water Distribution Network in a Supervisory Control System." *Control Eng. Pract.*, Vol. 6, (2000), 1177-1188.
- Clarke, D. W.; Mohtadi, C. and Tuffs, P. S. "Generalized Predictive Control - Part I, the Basic Algorithm." *Automatica*, Vol. 23, No. (2), (1987), 137-148.
- Clarke, D. W.; Mohtadi, C. and Tuffs, P. S. "Generalized Predictive Control - Part II, Extensions and Interpretations." *Automatica*, Vol. 23, No. (2), (1987), 149-160.
- Creasey, J. D. "Pump Scheduling in Water Supply: More Than a

- Mathematical Problem," In: B. Coulbeck and C. H. Orr (Eds.), *Computer Application in Water Supply, Vol. 2: Systems Optimization and Control*. Research Studies Press Ltd., (1988), 279-289.
- Cunha, M. C. and Sousa, J.** "Water Distribution Network Design Optimization: Simulated Annealing Approach." *J. Water Resour. Planning and Manage.*, Vol. 125, No. (4), (1999), 215-226.
- Cutler, C. R. and Ramaker, B. L.** "Dynamic Matrix Control Algorithm." *86th AIChE National Meeting*, Houston, TX, U.S.A., (1978).
- Dawkins, J. and Briggs, P. A. N.** "A Method for Using Weighting Functions as System Description in Optimal Control." *IFAC Symposium on Self-adaptive Control Systems*, Teddington, (1965).
- Eker, I. and Kara, T.** "Operation and Control of a Water Supply System." *ISA Transaction*, Vol. 42, (2003), 1-13.
- Gupta, Y. P.** "Control of Integrating Processes Using Dynamic Matrix Control." *Institution of Chemical Engineers Trans IChemE*, Vol. 76, Part A, (May 1998), 465-470.
- Henson, M. A.** "Nonlinear Model Predictive Control: Current Status and Future Directions." *Computers and Chemical Engineering*, Vol. 23, No. (2), (1998), 187-202.
- Jowitt, P. W. and Germanopoulos, G.** "Optimal Pump Scheduling in Water-supply." *ASCE J. Water Resour. Planning and Manage.*, Vol. 118, No. (4), (1992), 406-422.
- Mackay, M.; Thomson, M. and Soufian, M.** "A Bilinear Non-parametric Model Based Predictive Controllers." *Proceedings IFAC 13th World Congress*, California, (June 1996), 459-364.
- Mackay, M.; Thomson, M. and Soufian, M.** "Multivariable Model Predictive Control and Its Performance in the Presence of Inexact Modeling." *Inst. Meas. Control, International Symposium: The Application of Multivariable System Techniques*, University of Bradford, (March 1994), 293-308.
- Mousavi, H. and Ramamurthy, A. S.** "Optimal Design of Multi-reservoir Systems for Water Supply." *Adv. Water Resour.*, Vol. 23, (2000), 613-624.
- Rahul, S. and Cooper, D. J.** "A Tuning Strategy for Unconstrained SISO Model Predictive Control." *Ind. Eng. Chem. Res.*, Vol. 36, (1997), 729-746.

التحكم في نظام إمدادات شبكة المياه استناداً إلى نموذج التحكم التنبؤي

عادل عبدالرحمن¹، ونجيب ناشر²

¹ قسم الهندسة الميكانيكية، كلية الهندسة، جامعة صنعاء

² قسم الهندسة المدنية، كلية الهندسة، جامعة العلوم والتكنولوجيا

(قدم للنشر في 2008/6/21م؛ وقبل للنشر في 2009/7/18م)

الكلمات المفتاحية: شبكة إمدادات المياه، نموذج السيطرة التنبؤية، القيود.

ملخص البحث. يتطلب ازدياد الطلب على المياه بسبب النمو السكاني والتنمية الصناعية والاقتصادية تحسين إدارة المياه ونقل شبكات إمدادات المياه وتشغيلها وتحسينها. وتبحث هذه الورقة في تطبيق جهاز تحكم وجد أنه فعال في تحسين أداء نظام إمدادات شبكة المياه، والحفاظ على استقرار عملية معدل تدفق المياه، وتقليل التكلفة التشغيلية من خلال التحكم في سرعة الضخ. تعد خوارزمية التحكم التنبؤي النموذجي أكثر نظام تحكم آلي انتشاراً حاز على تطبيق واسع الانتشار في الصناعة العملية. وتبين النتائج أن تقنية التحكم التنبؤي النموذجي تنتج أداءً متطوراً أكثر من الأداء