

Characterization of Shale-Drilling Fluid Interaction Mechanisms Related to Wellbore Instability

Musaed N.J. Al-Awad* and B.G.D. Smart**

**Petroleum Engineering Department, College of Engineering, King Saud University,
P.O. Box 800, Riyadh 11421, Saudi Arabia, **Department of Petroleum Engineering,
Heriot-Watt University, Edinburgh, United Kingdom*

(Received 10/12/1994; accepted for publication 8/7/1995)

Abstract. Wellbore stability problems tend to occur during the drilling phase in shale sections, hence the understanding of shale-drilling fluid interaction mechanisms is essential if wellbore instability is to be avoided when drilling through shale sections. A review on the origin of shale electric potential is presented in this paper. Simple tests to be used at rig-site to characterize shale reactivity in the presence of drilling fluids were developed. These developed tests were verified by means of developing easy to use equipment made especially for this study. Borehole collapse problems that occur when drilling in shale sections were simulated using thick-walled shale cylindrical specimens. It was found that any increase in sample moisture content has led to a reduction in shale strength and decreased borehole stability, while the increase in wellbore pressure was found to improve borehole stability.

Nomenclature

A_w	= Water activity of shale.
API-FL	= Standard API filtration loss.
B1	= British location no. 1.
B2	= British location no. 2.
CP(t)	= Corrected penetration at time t.
FMS	= Friable mudstone.
d	= The diameter of the compaction cell.
D	= Shale dispersibility.
DF	= Drilling fluid.
E	= Saturated modulus of elasticity in compression.
h	= Recompacted shale sample thickness.
L	= Extension, or increase in length.

L_0	= Initial length
MC	= Moisture content
$P(t)$	= Penetration at time t
pH	= Hydrogen ion concentration
PV	= Plastic viscosity
S.G.	= Specific gravity
$S(t)$	= Swelling at time t .
W_1	= Weight of air tight container
W_2	= Weight of shale sample plus air tight container
W_3	= Weight of shale sample plus air tight container at equilibrium
W_d	= Weight of dispersed (unrecovered) shale
W_0	= Original weight of shale used
YP	= Yield point
ρ	= The native shale density
Ψ	= Unit swelling stress
δ	= Unit swelling strain
ϵ_H	= Swelling strain parallel to bedding at equilibrium
ϵ_V	= Swelling strains normal to bedding at equilibrium

Introduction

Shale is often the most troublesome of all formations to handle when drilling for oil and gas. Time and money spent on this problem, together with overall reduced profit margins, has led the oil industry to assign considerable time and efforts to solve the problem of unstable borehole in shales. On average, drilling problems due to wellbore instability are responsible for about 10 to 20% of the total drilling cost of a well. Further extensive statistical analysis reveals that 80 to 90% of these instabilities occur when drilling through shales [1]. Cost estimates for the industry outside the former communist countries are in the order of \$400-500 millions per year [2]. Problems generally build up in time, starting with fragmentation at the borehole wall, followed by transfer of the fragments to the annulus and finally culminating in problems such as "sticky hole", "tight hole", hole fill, stuck pipe etc. If hole cleaning is insufficient, consequences may include losing the hole, inability to log, and poor cement jobs because of extensive washouts. Shale is an argillaceous rock that contains water-sensitive clay minerals. When water is adsorbed, the rock swells. Material properties of shale rock under the influence of moisture have been extensively studied by Chenevert [3;4]. He demonstrated experimentally that the percentage of expansion (or strain) of the material is directly proportional to the weight percentage of moisture adsorbed by the material. Other researchers [5;6] have studied the effect of moisture change on shale mechanical properties. They found that the change in

moisture content is the predominant factor leading to alteration in shale mechanical properties and hence borehole instability. Hence most compressive wellbore failure problems occur in shales. Those problems can be solved by combination of chemical and mechanical approaches [7].

Shale Electric Potential

Substitution of one ion for another in the clay crystal lattice and imperfections on the crystal surface (especially at edges), lead to negative electric surface charges on clay particles. The magnitude of these negative charges is known as the “cation-exchange capacity” of the clay (meq/100 gm). These charges can arise from the isomorphous substitution of an ion by another of nearly equal size but lower valence. This occurs during crystallisation or formation of the mineral. If the substituting ion has a lower positive valence than the substituted ion, then the lattice is left with a net negative charge. The main substitutions found are aluminium for silicon in the silica tetrahedral unit, and ions such as magnesium, iron, or lithium substituting for alumina in the alumina octahedral unit. A second source of electric charge on clay structure is unsatisfied valence charges at the edges of the particles. These are referred to as broken-bond charges. The clay crystal lattice is continuous in two directions, but at the edges there must be broken bonds between oxygen and silicon or between oxygen and aluminium. These broken bonds attract hydrogen and hydroxyl from the surrounding water, leading to volume increase or so called swelling. Figure 1 shows schematics of these processes [8].

Experimental Work

Properties of testing fluids

Drilling fluids used in this study were formulated using the commercially available drilling fluids additives such as, bentonite, polymers, salts, etc. The composition and properties of these fluid are shown in Table 1.

Properties of shale samples

Four types of shale were used in this study due to its feasibility of coring and its reasonable reactivity when brought into contact with water. Semi-quantitative compositional analysis of all studied shales was investigated using XRD method and presented in Table 2.

Natural intact shale samples

Shale specimens in cylindrical shape are considered to be the easiest to prepare by coring from bulk samples. The techniques used for sample preparation take into

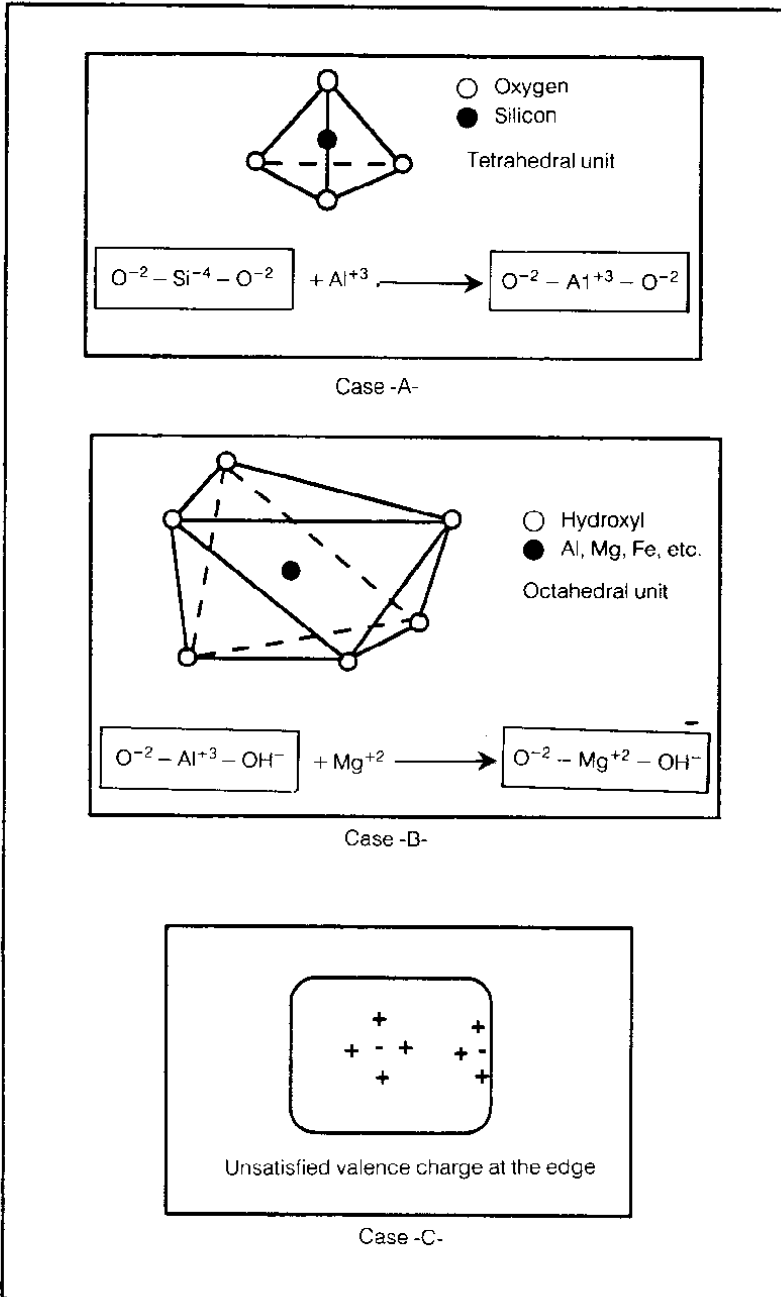

Fig. 1. Source of electric charge in clay structure [8].

Table 1. Composition of drilling fluids used in swelling tests

Drilling fluid types	Chemical composition	Fluid properties		
DF (1): Distilled water	-----	S.G. = 8.3 pH = 6.0	PV = 1	YP = 0
DF (2) Dispersed inhibited mud	20 g. Bentonite + 2 g. Lignosulfonate + 15 ml of 1N NaOH to give pH = 9.5 350 ml Distilled water.	S.G. = 8.7 pH = 9.5	PV = 14 API-F.L = 20	YP = 6
DF (3): Bentonite-XC-polymer- KCl	10 g. Bentonite + 15 g. Caustic to give pH = 10.5 + 0.5 g. XC-polymer + 10 g. KCl 350 ml Distilled water.	S.G. = 8.5 Ph = 10.5	PV = 16 API-F.L = 40	YP = 20
DF (4): Bentonite slurry	20 g. Bentonite + 0.5 g. Lime 350 ml Distilled water.	S.G. = 8.5 pH = 7.5	PV = 7 API-F.L = 20	YP = 11
S.G.	= Specific gravity, ppg.	pH	= Hydrogen ion concentration.	
YP	= Yield point, lb/100 ft ² .	PV	= Plastic viscosity, cp.	
API-FL	= Standard filtrate loss, cm ³ /30 min./100 psi.			

Table 2. Analysis of tested shale samples

Component	Percentage by weight				Wyoming bentonite
	FMS-shale	B1-shale	B-2shale	Total-shale	
Smectite	----	Traces	----	66-72	85
Illite	13	----	72	8-13	----
Chlorite	1	----	----	----	----
Kaolinite	58	70	----	13-14	----
Mixed-Layers	----	----	----	1-2	----
Quartz and Calcite	27	30	28	7	15
Organic matter	1	----	----	----	----

account that, the shale is significantly weakened and altered by water. The bulk shale samples were cut using dry-flush coring technique as shown in Fig. 2. The test samples are prepared to well defined specifications for sample dimensions and moisture content. In order to adjust the samples moisture content they were shaped to the

proper dimensions and then their moistures were adjusted to a predetermined values (native moisture content) without damaging the samples.

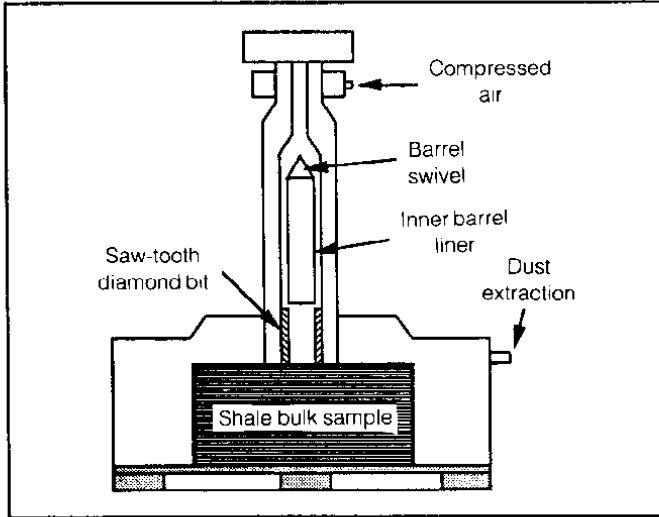

Fig. 2. Dry-flush coring arrangement

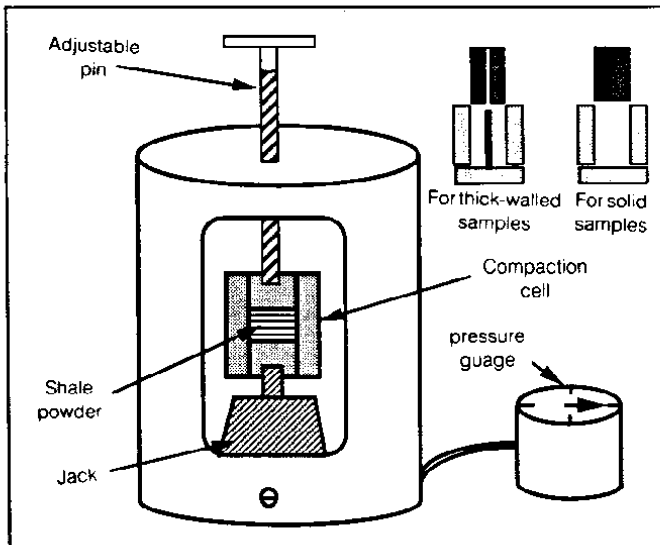

Fig. 3. Portable shale recompaction system.

Recompaction of shale samples

Most shale recompaction methods need a compression machine, which may not be available at rig-site. Hence, a new simple and effective portable compression system was fabricated, which can provide loads up to 60 kN and is suitable for use at rig-site. Also the previous methods produced a large sample from one compaction run and then cut the compacted sample into small pieces. This may alter the samples by producing microcracks exaggerating any result taken from testing of these samples. Two cells were developed to use with the fabricated compression system to reconstitute shale samples of 1.5 and 3 inches diameter from either fractured shale samples or from shale chips produced during drilling operations. Figure 3 presents a schematic of the fabricated compression system. Using this system, reconstituted shale samples have been produced in a routine basis. The following procedure was followed during the remoulding of the shale samples used in this study:

- (i) Native shale density is measured for comparison with those of the recompacted shale samples.
- (ii) Shale powder passing through the 200 mesh size is directed at 105°C overnight to remove any moisture it may contain.
- (iii) In order to determine the optimum remoulding water, a known weight of the dry shale powder and known volume of distilled water are compacted for a certain time, under a known constant pressure set. The process is repeated with increasing or decreasing the volume of water and compacting under the same pressure for the same period. By plotting the dry density versus the remoulding water volume (percent), the optimum mixing water is read from the plot as shown in Fig. 4.
- (iv) The optimum mixing (remoulding) water is used to prepare a mixture. Using the weight of this mixture, compaction cell dimensions, and native shale density, the sample length (thickness) required to produce samples with identical density to that of the native shale can be worked out from the following formula:

$$h = \frac{\text{Mixture weight}}{\left(\left\{ \frac{\pi_d^2}{4} \right\} \rho \right)} \quad (1)$$

- (v) The mixture is placed in the compaction cell and the load is increased gradually until the required sample length is reached. The sample is then left under load for about three hours, then extracted and placed in the shelf for 24 hours to equilibrate with the room humidity.

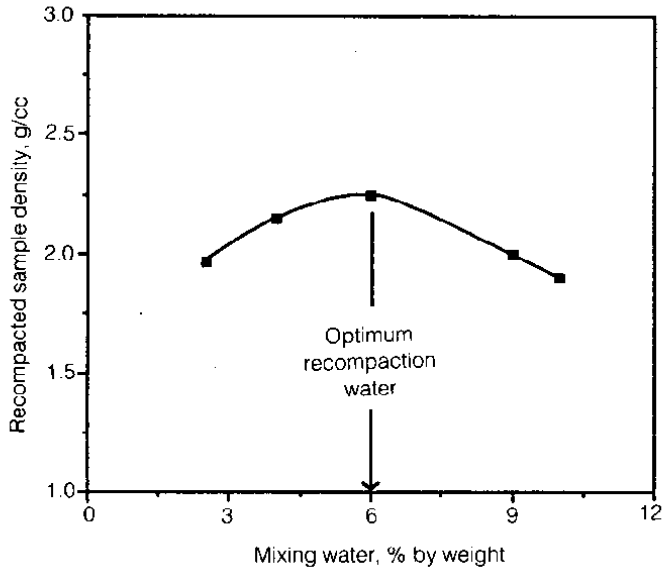

Fig. 4. Optimum recompacting water determination.

Moisture content determination

The moisture content of a shale on a weight basis is defined as grams of water contained in the sample per gram of the oven-dry shale multiplied by 100 to convert to percent. Moisture content should be measured as soon as the core is unwrapped from the protective casing. Chips from the center of the core should be selected to avoid the alteration zone that may be present near the outer face of the core. By minimizing the alteration of shale's moisture content during coring, storage, and instrumentation, it is possible to provide shale samples for testing which contain their native moisture content by applying the following methods:

- (i) Preserved shale sample is placed in air tight container of empty weight (W1).
- (ii) The container with sample inside is weighed (W2)
- (iii) The container with removed lid is placed in the oven at 105°C.
- (iv) The container is weighed every 12 hours after cooling and removing the lid.

When the weight (W3) is stabilised the moisture content is calculated using the following formula:

$$MC, \% = \left[\frac{W2 - W3}{W3 - W1} \right] \times 100 \quad (2)$$

Knowing the native moisture content, the altered samples can be restored to their native moisture content by using controlled humidity desiccators and the established adsorption isotherm.

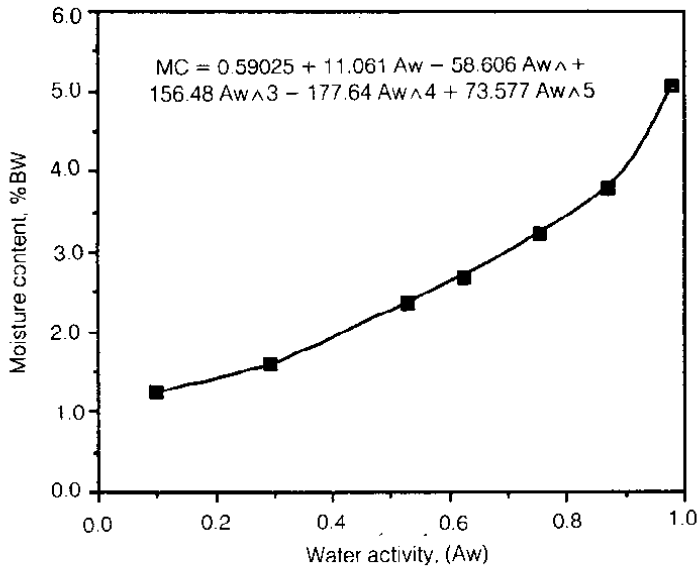

Fig. 5. The adsorption isotherm of FMS-shale.

Adsorption isotherm

An adsorption isotherm relates the amount of clay in a shale to its moisture content. As mentioned previously, the samples should be brought to the same water content level (preferably the native moisture content) in order to make useful comparisons between data. The adsorption isotherm is very useful in determining the amount of water a particular shale would gain or lose under various equilibrium conditions at constant temperature. A range of water activities can be achieved by using a number of saturated salt solutions placed in desiccators. Shale samples are placed in each of these desiccators and the equilibrium weight is determined for each desiccator, and then the water content is plotted versus water activities as shown in Fig. 5. Entering the adsorption isotherm plot with the native moisture content, one can determine the water activity needed to restore the shale samples to native moisture content. Once all the samples placed in the desiccators have been calibrated for water activity, and reached equilibrium (constant weight), they are available for any further test. The adsorption isotherm has many useful applications, as it is the primary relationship for establishing the swelling response of the shale. It is also an excellent way to determine the reactive potential of a shale. It provides the net effect

of all clays and ions present in the shale as related to their degree of hydration. It must be noted that when measuring the adsorption isotherm, only one type of shale should be in a single desiccator at the same time. This is because during adsorption, a possible error from equilibrating a number of adsorbents in the same desiccator at the same time could arise. Samples with relatively low adsorption reach equilibrium values quickly and then undergo some desorption before those with high adsorption come to equilibrium.

Free linear swelling test

The process of swelling is important, not only because it induces in-situ swelling pressure, but also results in a decrease in the material strength. A swelling test involves the saturation of air, oven dried, or humidity conditioned specimens and the measurement of their extension (swelling) in the direction of their longitudinal axis due to the uptake of water. The unit swelling strain may be calculated using the following expression:

$$\delta = \frac{\Delta L}{L_o} \times 100 \quad (3)$$

In addition, by comparing the result obtained from groups of specimens subjected to a standard uniaxial compression test before and after saturation, the magnitude of the strength reduction due to the presence of water can be determined [4-6]. If the saturated modulus of elasticity in compression is also found, the unit swelling stress can be calculated as follows:

$$\Psi = \delta \cdot E \quad (4)$$

Several mechanisms have been proposed to explain the influence of water on strength reduction in rock [7] such as fracture energy reduction, capillary tension decrease, pore pressure increase, frictional reduction, or chemical and corrosive deterioration. Which mechanism predominates will depend on the rock type. Based on the swelling tests, various drilling fluids can be screened in order to choose fluids which develop an inhibitive action on shale swelling. Swelling was measured by a computer aided swellmeter. The swellmeter is a device that measures swelling of a shale pellet after the shale has been in contact with drilling fluid. The amount of swelling that the shale undergoes after it contacts the drilling fluid is a measure of the reactivity of the shale to the fluid. The swellmeter (see Fig. 6) consists of a mud reservoir, Shale chamber, linear variable differential transducer (LVDT) and A/D converter and computer. The mud reservoir holds the mud until the test is ready to start.

The shale pellet (cored from intact bulk sample or recompacked by means of the designed compaction cell) is placed in the shale chamber which confines the shale between screens and confines swelling to the vertical direction.

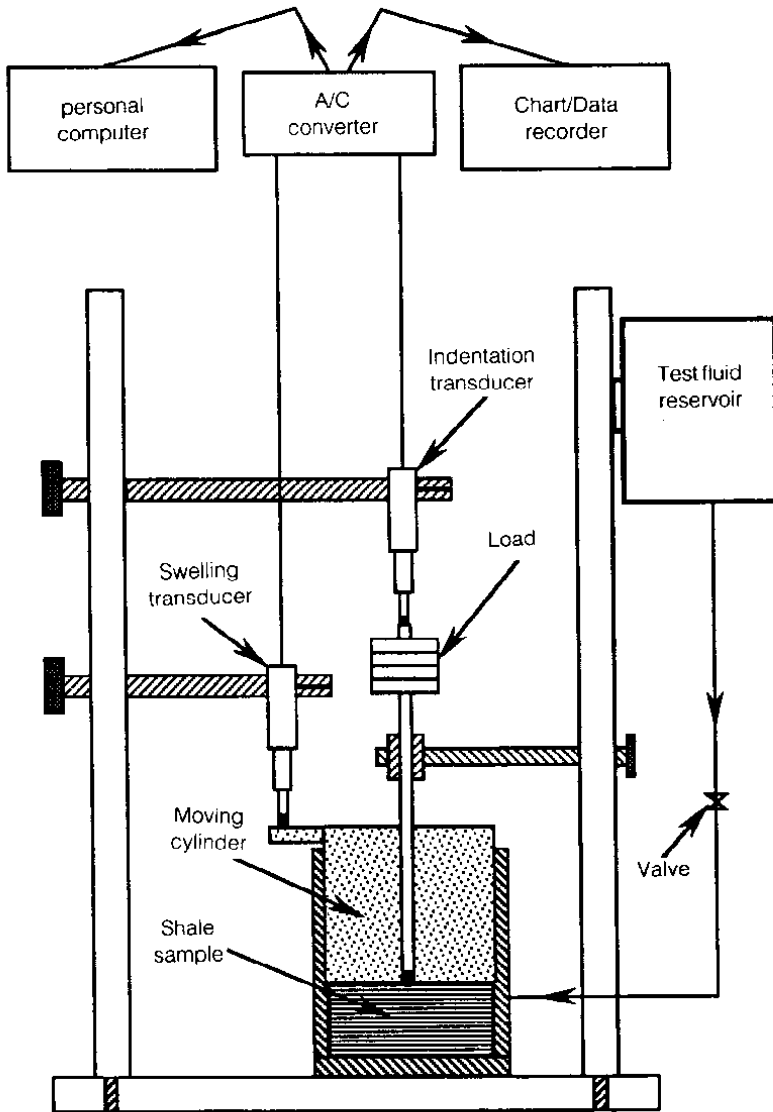

Fig. 6. Schematic diagram of the computer aided swellmeter and penetrometer.

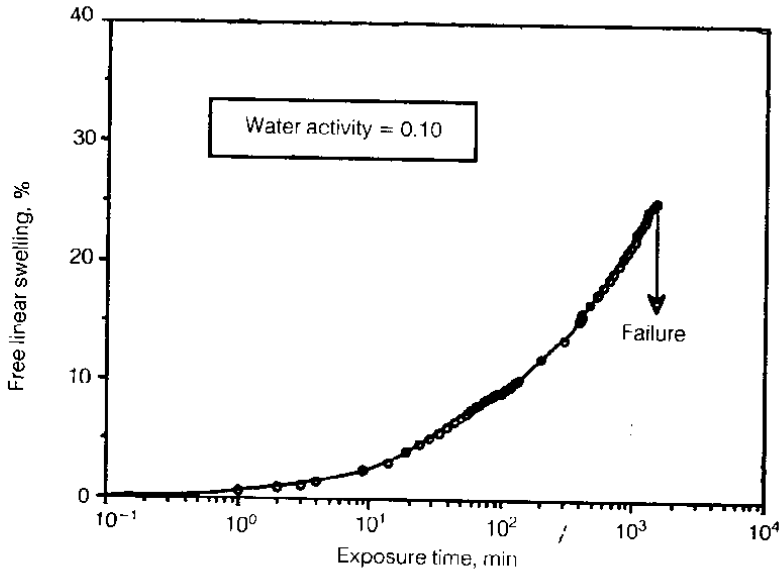
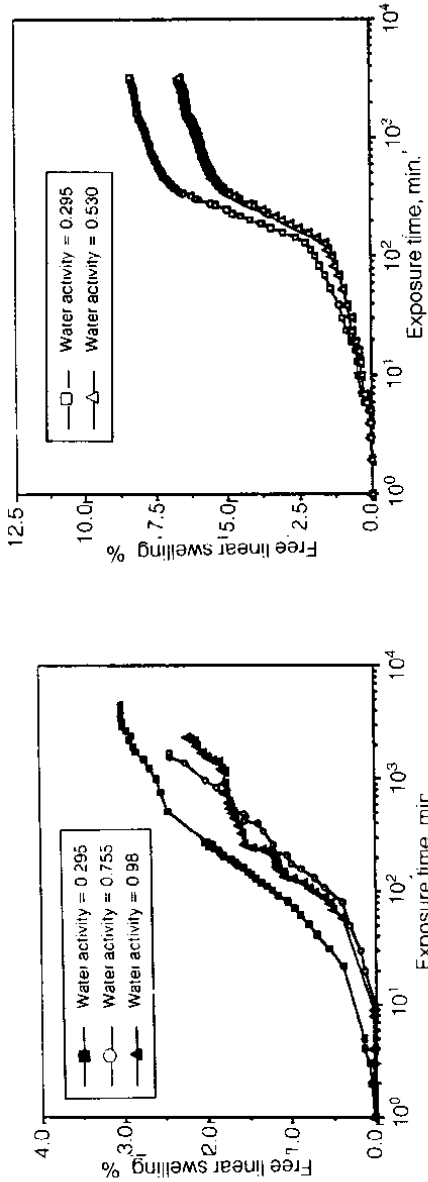
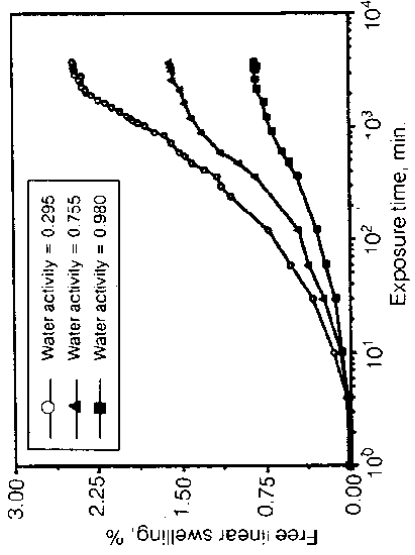

Fig. 7. Free linear swelling of recompacted Wyoming bentonite when exposed to distilled water.

The swelling of the shale causes the LVDT sensor to rise altering the inductance of the transducer and generating a voltage change which is sensed by the A/D converter. The A/D converter status is monitored by a computer at short intervals and results, in terms of per cent volume expansion of the shale, are recorded for the duration of the test. Up to six tests can be performed simultaneously. A 16-36 hours test duration is generally used and the recording interval is set to 5 to 30 min. In order to evaluate this method shale samples were used, both cored from intact or compacted using the fabricated compaction rig. In this test it is attempted to investigate the reactivity of tested shales as well as the effect of initial moisture on shale swelling behavior. Recompacted pellet made from Wyoming bentonite was tested using distilled water as shown in Fig. 7. Bentonite is the most known reactive clay mineral in shales. Figure 8 represents the free linear swelling of B1, Total and B2 shales when conditioned at different initial relative humidities. It is clear that shales develop less swelling when they have high moisture content. This is believed to be due to the satisfaction of the clay minerals due to gain of initial moisture. Figure 9 shows the difference in swelling between intact and compacted B1 and B2 shales when brought into contact with distilled water, while Fig. 10 shows the effect of various drilling fluids on the recompacted B1, B2 and Total shales. It is clear from these tests that bentonite has high ability to swell when contaminated by drilling fluids while the tested other shales have little swelling ability compared to bentonite. This is due to low reactive clay contents of these shales. The intact shale has less swelling ability when compared



(a) Recompacted B1-shale



(c) Recompacted B2-shale

Fig. 8. The effect of initial moisture content (water activity) on the free linear swelling of recompact shales when exposed to distilled water.

(b) Recompacted total-shale

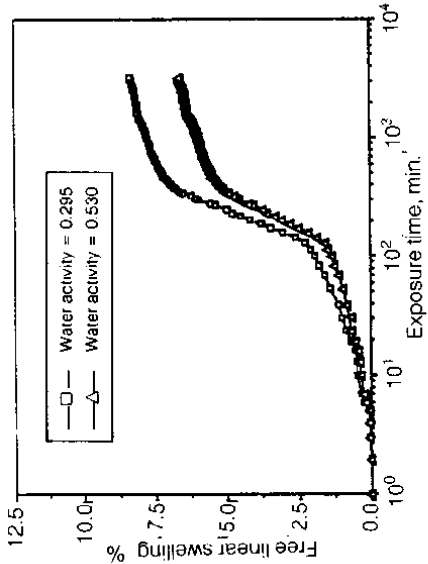

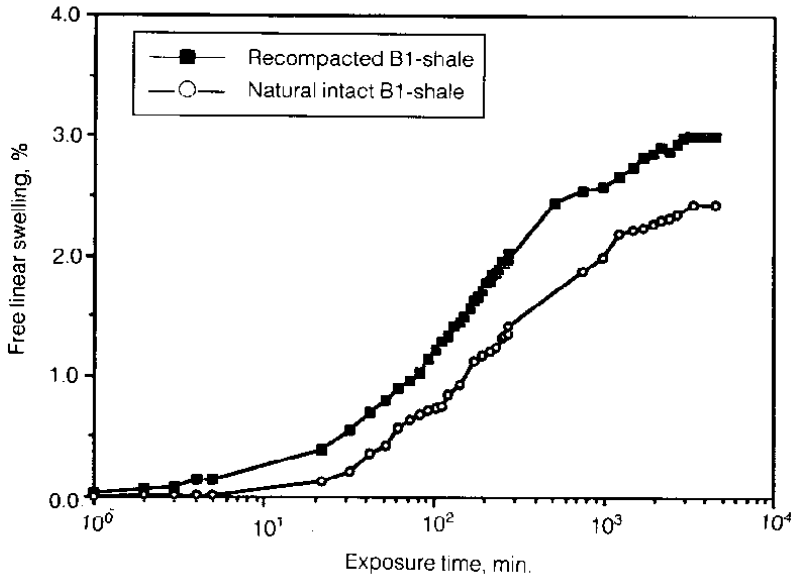

(a) B1-shale

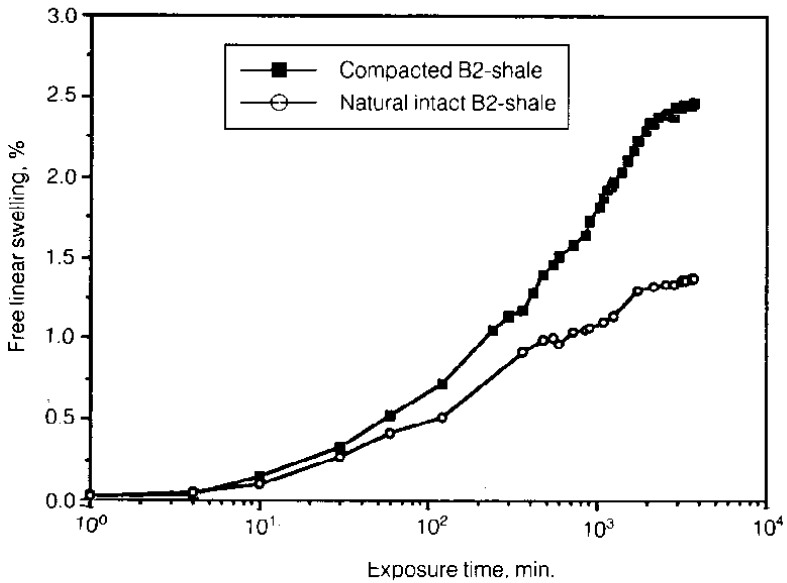

(b) B2-shale

Fig. 9. Comparison between free linear swelling of recompact and natural intact shales when exposed to distilled water.

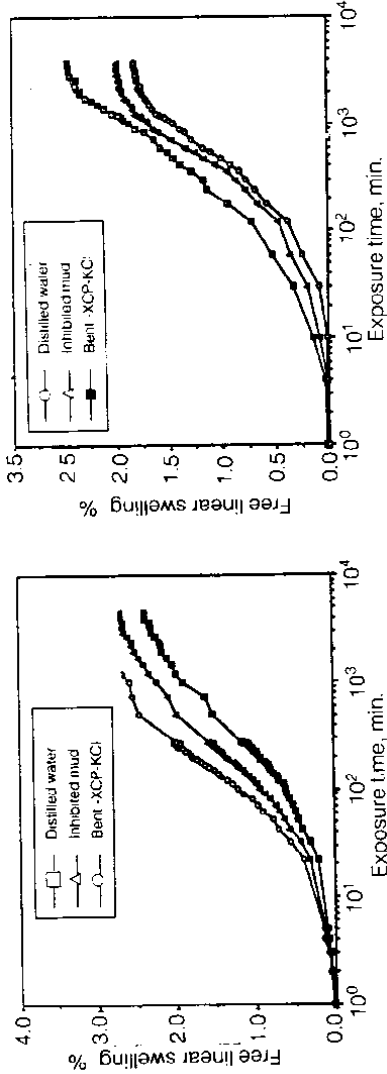

(a) Recompacted B1-shale

(b) Recompacted B2-shale

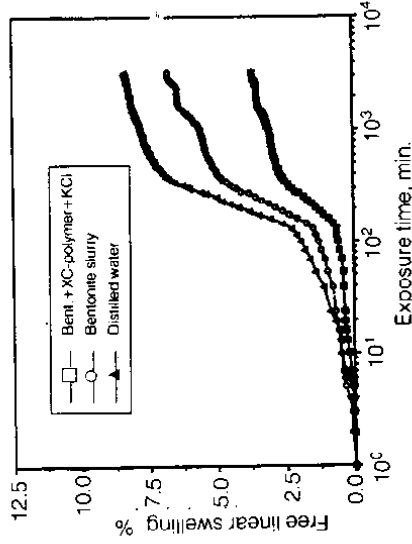

(c) Recompacted total-shale

Fig. 10. The effect of drilling fluid type on the free linear swelling of recompact shales when exposed to various drilling fluids.

with the recompacted samples because these later samples have less bonds between clay platelets as they are destroyed during the crushing process when preparing the recompacted samples.

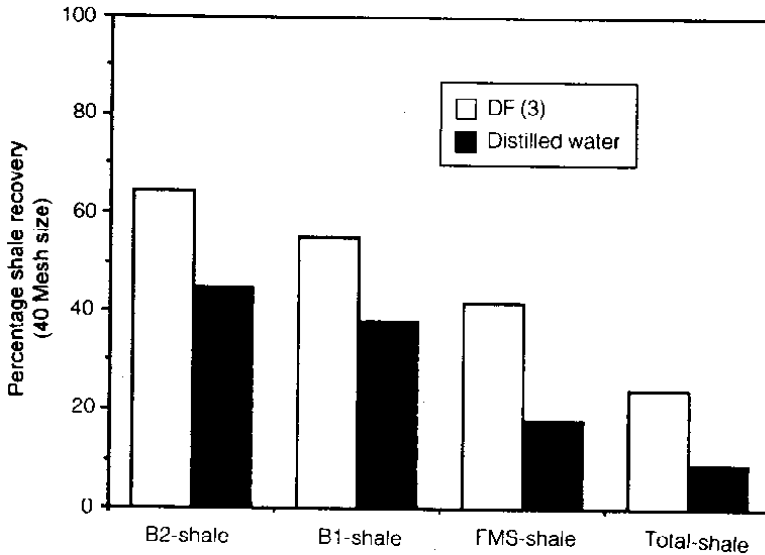

Fig. 11. Dispersibility test result for various types of shale.

Dispersibility (hot-rolling) test

The dispersibility (hot-rolling) test is a common procedure normally used to measure the interaction between drilling fluids and shale. Figure 11 shows the percentage recovery of various shales when rolled in distilled water and DF (3). Shale dispersibility into drilling fluid is a function of shale particle size (*i.e.* exposed surface area per unit weight of sample), the drilling fluid viscosity, shale compaction, rolling time and speed, and test temperature. The laboratory Roller oven, which is composed of 400 ml high temperature stainless steel ageing cells is used for this test. Shale dispersibility in percentage is calculated from the following equation:

$$D = \left\{ \left(\frac{W_d}{W_o} \right) \times 100 \right\} \quad (5)$$

Test general procedure is as follows:

- (i) Crush the shale sample using mortar and pestle.
- (ii) Collect suitable shale for the dispersion test using standard sieves.

- (iii) Weigh 20.0 grams of shale sample and add to 1 bbl equivalent of each test fluid, prepare a blank test using distilled water for comparison.
- (iv) After hot rolling for 16 hours, cool the samples and use an 80-mesh screen to recover the undispersed shale from the test fluids. Wash mud solids from the recovered shale with 10% KCl solution or diesel oil when using oil-based drilling fluids.
- (v) Dry the recovered shale and determine its weight. Determine the grain size of the recovered shale using 40-mesh and/or 20-mesh screens and report the percent recovery over each screen size used.

Disintegration test

This test is very simple and can give an indication how a shale sample will overcome the strength reduction of the drilling fluid. This test is composed of two parts. The first part is called the static or immersion test which is simply placing of shale balls in various drilling fluids and determines which one has displayed the least amount of swelling and disintegration. The two critical values are the percent shale recovered and visual observation (integrity or disintegration). When the balls remain intact and recovery is high, the shale is least affected. The second part of the test is called the dynamic test, where the balls are placed in a container which is filled with the test fluid. The container is then placed in hot water bath to control the temperature. The test fluid is then agitated by means of a lab mixer. While the sample is clamped in position, the shale resistance to indentation is measured before and after stirring. The relation between strength and swelling is established by this test.

Continuous indentation test

A new test was developed in order to measure rock resistance to indentation as shown in Fig. 6. This test predicts the effect of testing fluid on rock strength by continuous recording of penetration depth, and provides a clear idea about time dependent failure as well as the establishment of the relationship between free linear swelling and indentation (penetration). This test provides a continuous data recording process from the time of the dry rock is placed in the cell until full saturation is reached, while the classic method (Humboldt penetrometer) provides information only at starting (dry rock) and at final (fully saturated rock) points, while the data in between cannot be provided continuously. Since swelling and penetration (indentation) processes are opposing each other, the net penetration occurred during test can be therefore calculated as follows:

$$CP(t) = S(t) - P(t) \quad (6)$$

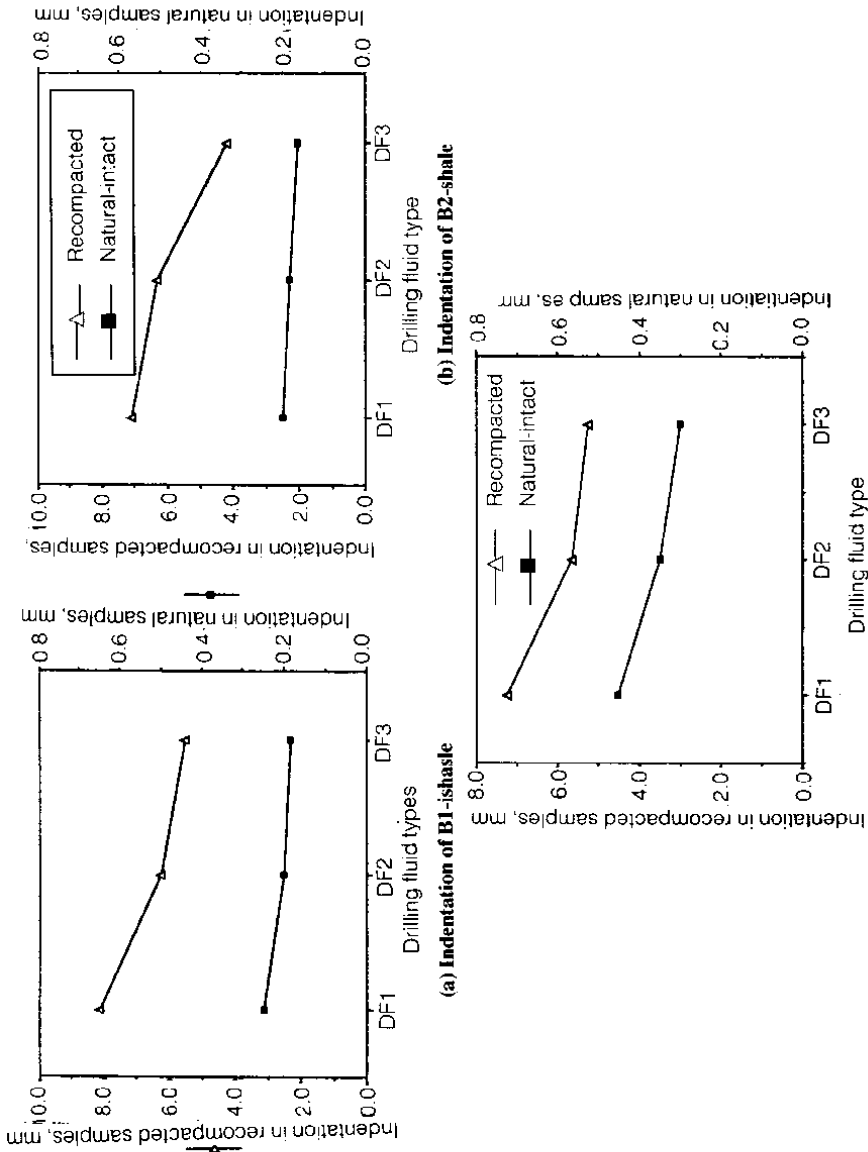

Fig. 12. Shale indentation after 24 hours of exposure of various drilling fluids.

Plots of net penetration and swelling versus time, will provide a comparison between swelling and indentation and hence predict the effect of drilling fluid on the stability of test specimen. Also, the time dependent penetration can be observed which gives a direct prediction of the overall stability. Figure 12 describes the penetration process of three shales for both native and recompacted samples when saturated with distilled water. Native shale samples showed higher resistance to indentation compared with the recompacted samples. Recompacted shale samples showed a similar indentation trends as those of natural shale samples, therefore provided an indication about the behavior of natural shale when brought in contact with a drilling fluid. Therefore, this test has the ability to be used as a fluid selection guide when characterizing borehole instability.

Anisotropy factor measurement

In this technique the shales were cut into cylindrical specimens, and strain gauges were attached diametrically opposed on the samples. The leads were connected and strain gauges coated with water proof material. These strain gauges were arranged to measure swelling strains in both vertical and horizontal directions (normal and parallel to bedding planes). The samples were then placed in desiccator containing saturated salt solutions, and the leads passed through the rubber stopper (bung) on the top of the desiccator, connected to a specially designed box containing a set of resistors to complete full bridges. The output voltage from these bridges was connected to a data logger to record the strains at chosen time intervals. The test was terminated when the strains became constant as shown in Figs 13,14 and 15. Plotting the swelling strains at equilibrium normal and parallel to bedding planes at various water activities (relative humidity) will yield a straight line. The anisotropy factor in this case is equal to the slope of the straight line:

$$\text{Anisotropy factor} = \left[\frac{\epsilon_H}{\epsilon_V} \right] \quad (7)$$

From these tests, it can be seen that the lateral strains are very small compared to vertical ones. This difference in magnitude between horizontal and vertical swelling strains is believed to be due to high shale density (2.65 g/cc) and alignment of clay minerals during sedimentation. This technique can help in determining the anisotropy factor of sensitive shales without affecting the rock mechanical properties. It is clear from this technique that when a shale specimen adsorbs water up to a level above its initial moisture content, swelling strains in both directions normal and parallel to bedding planes are generated. These strains are able to produce or enhance microfractures and/or separate the sample through its bedding. The slope of

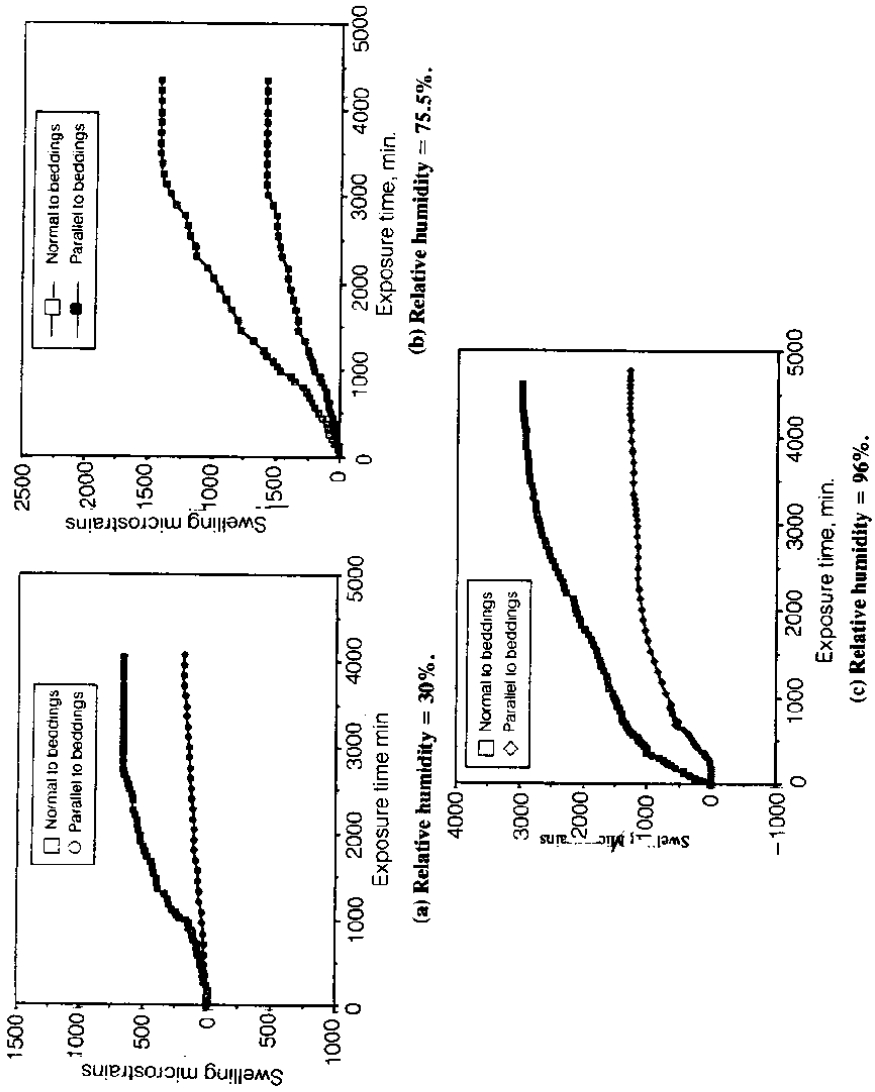
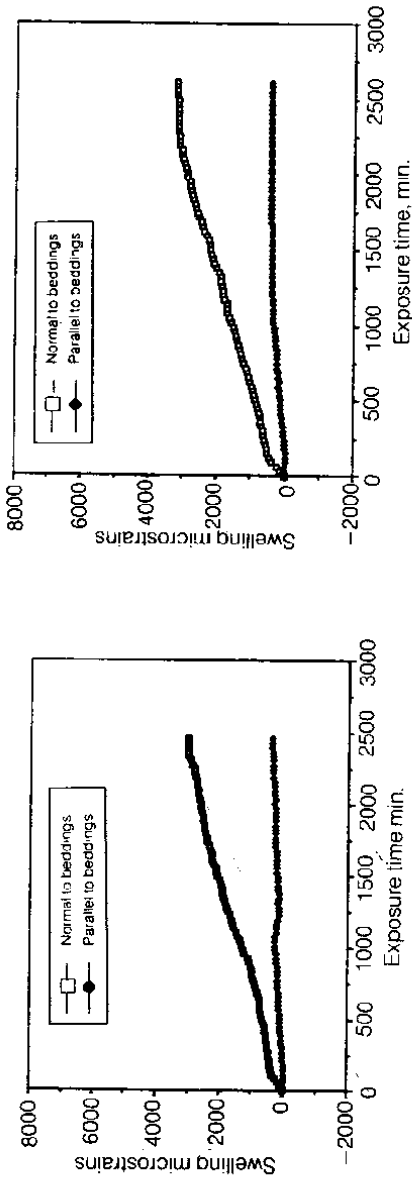

Fig. 13. Anisotropy factor determination of natural intact FMS-shale.



(b) Relative humidity = 53%.

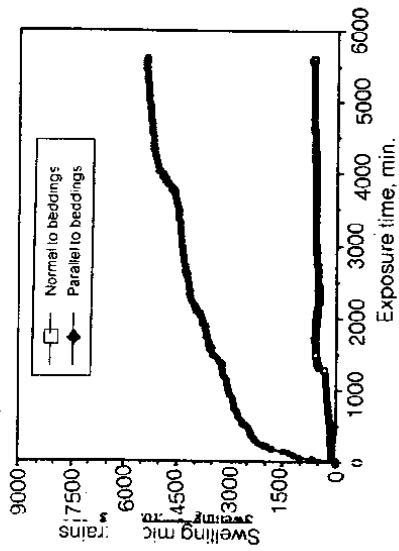

Fig. 14. Anistropy factor determination of natural intact B2-shale.

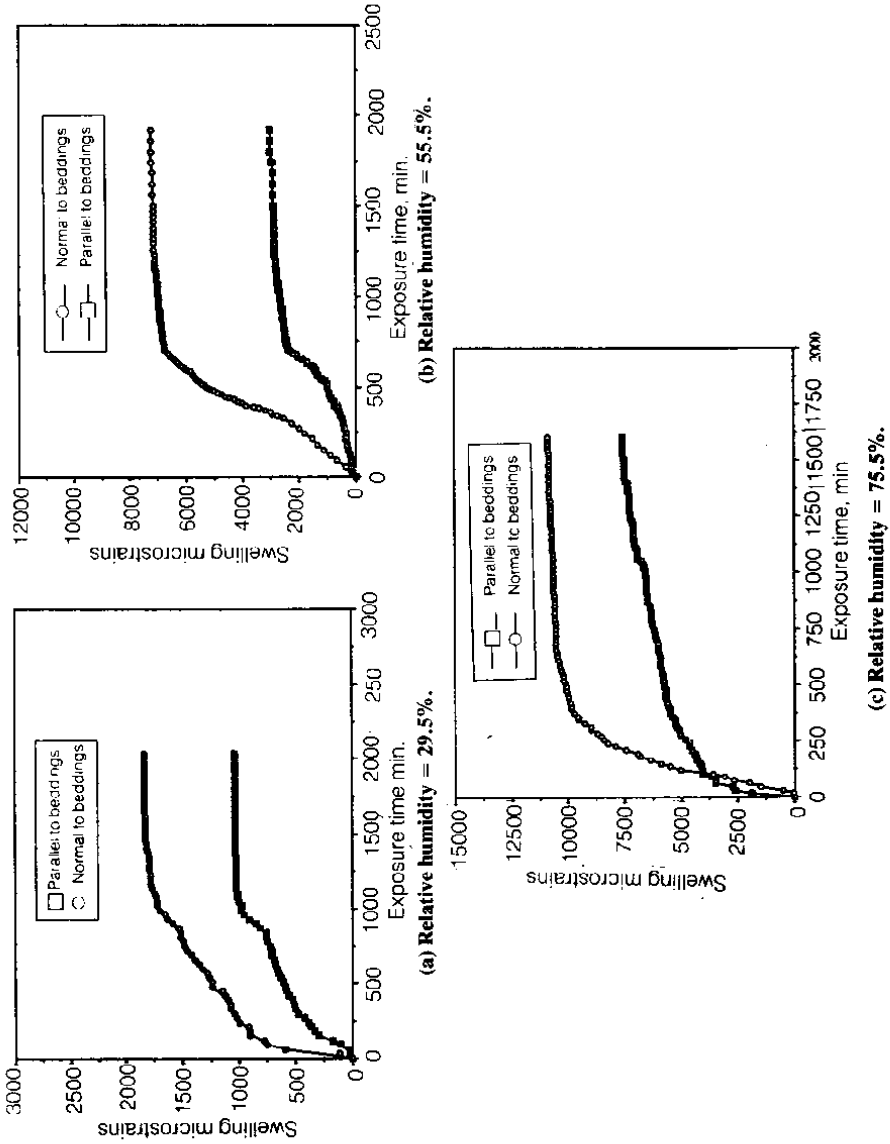

Fig. 15. Anisotropy factor determination of natural intact total-shale.

the straight line fitting these data points is the anisotropy factor for the tested shale as shown in Fig. 16.

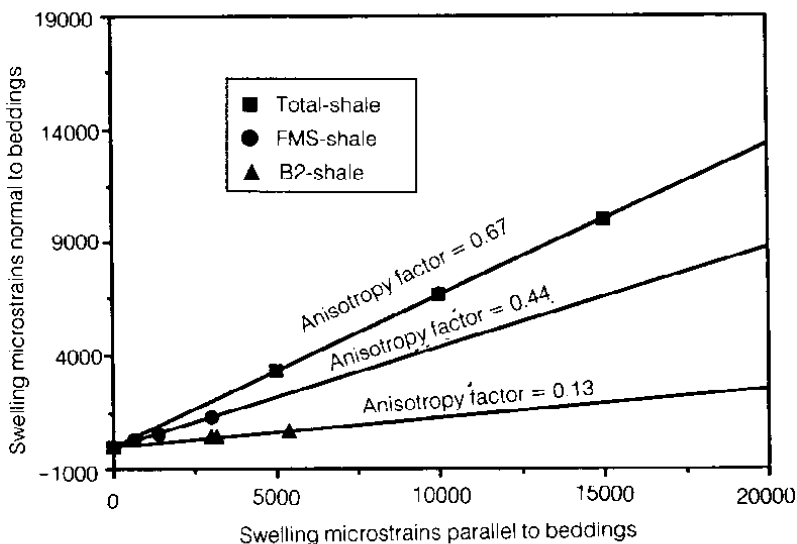

Fig. 16. Relationship between swelling microstrains normal and parallel to bedding planes for three types of shale exposed to variable relative humidity.

Pore pressure penetration and borehole instability

Pore pressure in the failed zone around the wellbore will rapidly equalize with the wellbore pressure, resulting in a rapid loss of support pressure. When the mud pumps are stopped, the mud pressure decreases to its static value and subsequent swab pressure may reduce the wellbore pressure even further. This results in radial tension in the failed zone while may lead to detachment of the failed rock. In order to investigate the effect of pore pressure penetration caused by shale-drilling fluid interaction on borehole stability, an extension of the conventional thick-walled cylinder test was carried out on preserved natural thick-walled cylindrical shale samples cored from FMS-Shale with length to diameter ratio of 2.5 and inner to outer diameter ratio of 1.67. Figure 17 shows the testing arrangement. The loading procedure followed during this test is as follows:

- (i) The thick-walled cylindrical shale sample is consolidated under hydrostatic loads to simulate *in-situ* shale conditions by increasing the axial load and the confining pressure (internal wellbore pressure (P_{in1}) is maintained at atmospheric) simultaneously to a predetermined pressure, with hole stability is main-

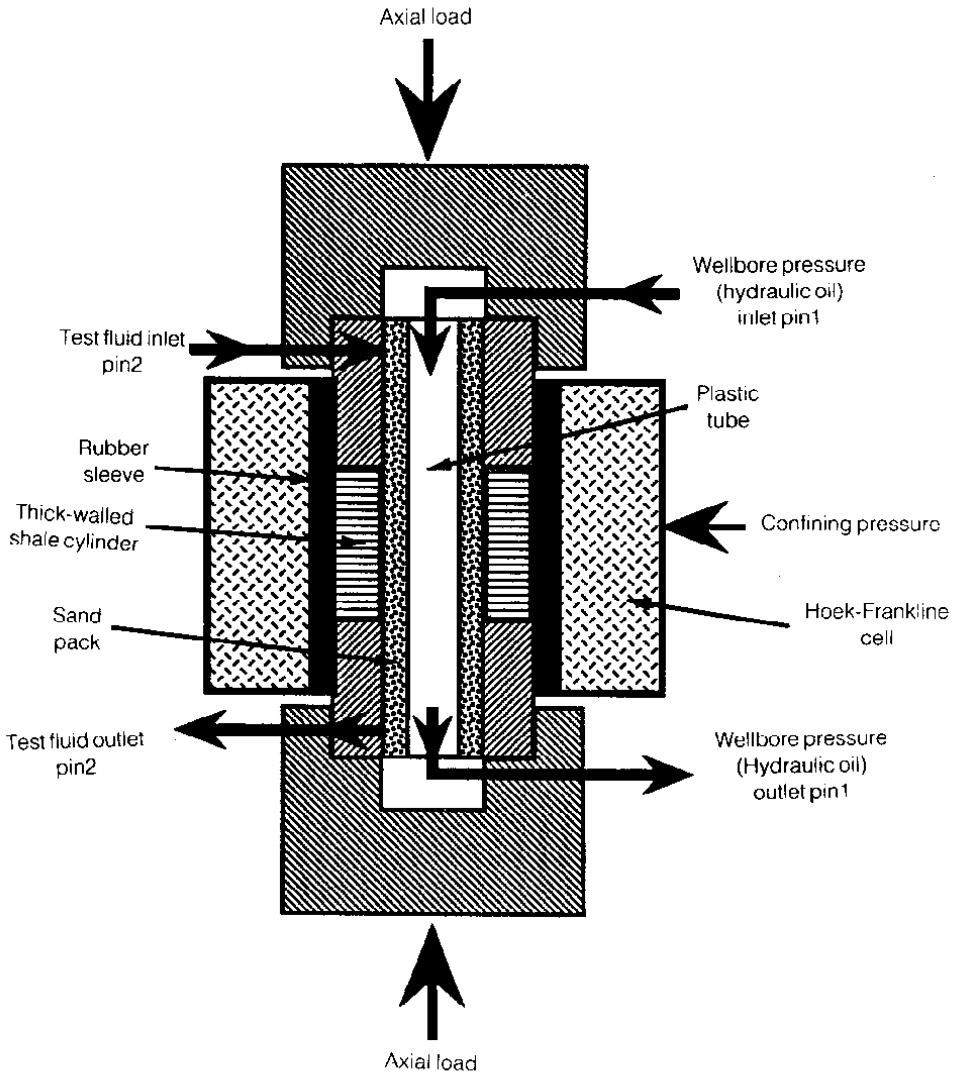

Fig. 17. Schematic diagram of the borehole collapse test arrangement.

tained. Pore pressure is allowed to drain off and the pressure is maintained until pore pressure equilibrium takes place.

- (ii) The drilling process is simulated by maintaining the confining pressure while increasing the axial load until failure is noticed, whereby the internal wellbore pressure is immediately raised to maintain hole stability.

- (iii) Thereafter, drilling fluid is injected via test fluid inlet (P_{in2}) through the sand-filled annulus between the internal plastic tube and the internal shale specimen surface (wellbore surface). The other alternative is that no fluid is injected in order to simulate non reactive shale with non penetrating drilling fluid.
- (iv) The test further consists of increasing the axial load until failure is reached, where the internal wellbore pressure (P_{in1}) is increased to recover this failure. This process is repeated until non-recoverable failure is reached and the test then is terminated.

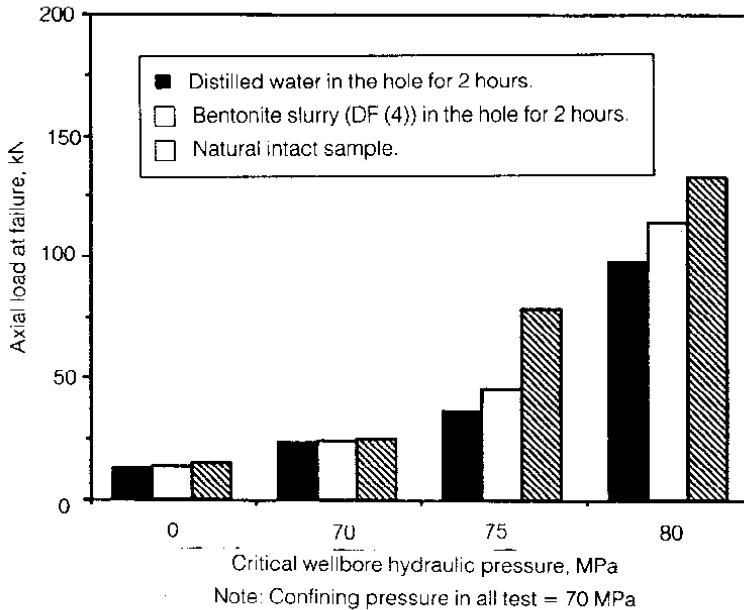

Fig. 18. Borehole collapse test result for natural intact FMS-shale.

Figure 18 shows how the dry natural shale sample can maintain stability under higher axial load and under low wellbore pressure compared to the fluid-interacted sample. Bentonite slurry (DF (4)) improved the strength of the tested samples when compared with the distilled water case. This is believed to be due to the attraction of water molecules into clay particles existing in bentonite which minimized shale-filtrate interaction. This is probably due to the weakening effect of the drilling fluid on the bonds existing between clay particles forming the shale. Swelling process also reduces shale strength by generating repulsive forces between clay particles.

Results and Discussions

One method for determining the compatibility between shale and drilling fluid is to obtain samples from the formation and subject them to direct swelling tests. Unfortunately, most field practices today do not include procedures which produce preserved, intact shale samples. Instead altered samples are obtained. Therefore, a simple technique was developed in this study to produce recompacted shale specimens made from shale fragments obtained either from the altered cores or from shale shaker and use them in various instability tests as shown in Figs. 3 and 4.

Shale Adsorption Isotherm is an excellent method for determining the relative potential of a shale as shown in Fig. 5. It provides the net effect of all clays and ions present in the shale as related to their degree of hydration.

Swelling was measured by the developed apparatus shown in Fig. 6. It was found that as the initial moisture content increases, the degree of swelling decreases as shown in Fig. 8. This is believed to be due to the satisfaction of the shale with the initially adsorbed water.

Recompacted shale samples have higher swelling magnitudes compared to the natural samples as shown in Fig. 9. This is because the natural bond between clay particles was destroyed during recompaction process as well as the random orientation of the clay platelets in the recompacted samples. Bentonite-XC-Polymer-KCl drilling fluid has a great ability to control shale swelling. This is due to the ability of XC-Polymer to plaster shale pores and the substitution of the existing ions by Calcium ion (K^{++}) which has the ability to attract clay platelets closer to each other as noticed in Fig. 10.

Figure 11 shows how the use of proper drilling fluid can improve the recovery of shale cuttings and hence maintain the desired rheological properties and reduce hole erosion.

Indentation is directly related to mechanical properties. It was found that natural shale has higher resistance to indentation compared to recompacted shale as shown in Fig. 12. Also, it can be noticed that similar indentation trend is existing for both natural and recompacted shales when exposed to drilling fluids. Thus the effect of drilling fluid-shale interaction on natural shale properties can be predicted using recompacted samples from the same formation.

Shale anisotropy factor is required in most wellbore instability models. Anisotropy factor is unique and it is independent of the magnitude of water adsorbed as shown in Figs. 13,14 and 15. All the tested shales have an isotropy factor less than unity, therefore, they are considered as anisotropic shales as shown in Fig. 16.

Borehole collapse test is simulating both the effect of pore pressure penetration and shale-drilling fluid interaction. It was found that higher wellbore pressures were required to maintain hole stability in hydrated shales as shown in Fig. 18.

Conclusion

From the previous experimental results, the following conclusion may be derived:

- 1) Successful drilling of troublesome shales requires evaluation of shales during the drilling process at the well-site.
- 2) The simple tests and procedures presented in this paper can rapidly be used to recompact shale samples and determine the extent of shale-drilling fluid interaction. Hence, proper drilling fluids can be selected to drill the encountered shale safely.
- 3) Shales must be brought to the same level of water content before testing in order to make useful comparisons between experimental data.
- 4) Linear swelling of Bentonite (rich in smectite clay mineral) was found ten folds greater than that of B1- and B2-shales.
- 5) The use of Bentonite-XC-Polymer-KCl drilling fluid minimized and instability of the tested shales such as swelling, indentation and dispersibility. Therefore, this composition is recommended for drilling reactive shales.
- 6) Anistropy factors of all the tested shales were less than one, therefore, they are considered as anisotropic shales.
- 7) The increase in water content, i.e. the degree of shale swelling may alter shale mechanical properties and disturb borehole stability. This process may be clearly observed in swelling-indentation tests.
- 8) Support given by wellbore pressure to the sides of the hole will decrease with time if equilibrium between pore fluid and drilling fluid takes place.
- 9) When pore fluid penetration exists, higher support (wellbore pressure) is required to maintain borehole stability.

- 10) Mud filtrate movement from or into shale can be achieved by either of two ways: firstly, using drilling fluids that have the ability to plug and plaster shale pores and secondly, the formulation of chemically active drilling fluids.

References

- [1] Santarelli, F.J.; Chenevert, M.E. and Osisanya, S.O. "On the Stability of Shales and Its Consequences in Terms of Swelling and Wellbore Stability." Paper No. 23886 on the IADC/SPE Drilling Conference, New Orleans: Louisiana, Feb. 18-21, 1992.
- [2] Bol, G.M. and Wong, Sau-Wai. "Borehole Stability in Shales." SPE 24975, *European Petroleum Conference*, Cannes: France, Nov. 16-18, 1992.
- [3] Chenevert, M.E. "Shale Alteration by Water Adsorption." *JPT*, Sept., 1970, 1141-1148.
- [4] Chenevert, M.E. "Adsorptive Pore Pressure in Argillaceous Rocks." *Proc. 11th Symposium on Rock Mechanics*, Univ. of California: Berkeley, June 16-19, 1969.
- [5] Colback, P.S.B. and Wijd, B.L. "The Influence of Moisture Content on the Compressive Strength of Rock." *Proc. of 3rd. Canadian Symp. on Rock Mechanics*, Toronto, 1975.
- [6] Hall, A.H. and Mody, F.K. "Experimental Investigation of the Influence of Chemical Potential on Wellbore Stability." Paper No. 23885 on the IADC/SPE Drilling Conference, New Orleans: Louisiana, February 18-21, 1992.
- [7] Eeckhout, V.E.M. "The Mechanisms of Strength Reduction Due to Moisture in Coal Mine Shales." *Int. J. Rock Mech. Min. Sci. & Geomech. Abstr.*, Elsevier Science Ltd., Exeter, U.K. 13, (1976), 61-67.
- [8] Young, R.N. and Warkentin, B.P. "Soil Properties and Behavior." *Development in Geotechnical Engineering*, No. 5, Amsterdam, The Netherlands: Elsevier Scientific Publishing Company, 1973.

تحديد نظم تفاعل سائل الحفر مع صخور الطفل وعلاقتها بتهدم البئر

مساعد ناصر جاسم العواد* و براين سهارت**

* قسم هندسة النفط، كلية الهندسة، جامعة الملك سعود، ص. ب. ٨٠٠،

الرياض ١١٤٢١، المملكة العربية السعودية و** جامعة هيريو وات،

إدنبرة، المملكة المتحدة

(سُلّم في ١٠/١٢/١٩٩٤م؛ قُبِل للنشر في ٨/٧/١٩٩٥م)

ملخص البحث. إن مشكلة عدم الثباتية في آبار النفط والغاز غالباً ما تقع خلال عملية الحفر بين طبقات الصخور الطينية (الطفّل) ولذلك فإن فهم ميكانيكية التفاعل بين سائل الحفر وتلك الصخور مهم جداً لتفادي مشكلة التهدم في الآبار عند الحفر خلال طبقات الصخور الطينية (الطفّل). لقد تمّت مراجعة الجهد الكهربائي (درجة التفاعلية) للصخور الطينية. وتمّ تطوير اختبارات حقلية تستخدم لتصنيف الصخور الطينية حسب درجة تفاعلها مع سائل الحفر. وتمّ التأكد من صحة تلك الاختبارات بتصميم أجهزة عملية خصيصاً لهذه الدراسة. كما تمّت محاكاة مشكلة انهيارية البئر خلال عملية الحفر في طبقات الصخور الطينية معملياً باستخدام عينات أسطوانية مجوفة، ووجد أن الزيادة في المحتوى المائي للعينة قد أدت إلى تقليل قوة التحمل، وبالتالي قلّلت من ثباتية البئر. بينما وجد أن الزيادة في الضغط الهيدروستاتيكي لسائل الحفر قد أدت إلى تحسين ثباتية البئر.