

Evaluation of Multi-stage Framing and Retransmission Overheads with Emphasis on IBM-SNA

Imad Al-Sughaiyer *, **Abdullah Al-Dhalaan ****, **Saad Haj Bakry ****

** King Abdulaziz City for Science and Technology*

*** King Saud University, Riyadh, Saudi Arabia*

(Received 10 January 1995; accepted for publication 18 June 1995)

Abstract. This paper presents mathematical and computer tools for the evaluation of data overheads in message streams considering a two-stage framing and a retransmission protocol for error correction: a typical case of IBM-SNA with SDLC. The paper also describes an application that illustrates the use of the tools and that shows how the various factors affecting the overheads can be balanced, so that minimum overheads and consequently maximum throughput can be achieved. The general approach used in the paper would help in the future evaluation of data overheads for other framing and transmission systems.

Introduction

In data networks, data overheads represent one part of the cost paid for controlling the operations of such networks. One research objective associated with data overheads has been the evaluation of the size of data packets transmitted through the network for the purpose of reducing the effect of the overheads on network utilization. Important examples of research work related to this objective include the work reported by Majithia and Bhar [1], and the work reported by Schwartz [2].

Majithia and Bhar studied the optimum fixed packet size that minimizes the

proportion of overheads in the transmitted data, considering operational overheads resulting from the network operations, and blank padding overheads resulting from increasing the bits of smaller packets to reach a specific fixed size. Schwartz reported work concentrated on finding the optimum packet size that maximizes network throughput considering network operational overheads, and the retransmission overheads resulting from the retransmission of packets received in error [1, 2].

The aim of the work presented here is to evaluate the data overheads resulting from a two stage framing of messages and retransmission against the framing sizes, and the bit error rate: BER. This is a typical case in SNA (IBM System Network Architecture) where framing is done for both: the application buffer: AB, and the Request/Response Unit: RU, with error control using retransmission according to SDLC (Synchronous Data Link Control) [3]. This helps the management of networks based on SNA, (or based on similar principles) such as our GULFNET (the research computer network of the Gulf Cooperation Council Countries), in making decisions about AB and RU sizes under different circumstances. The work involves the derivation of a general model that enables the required evaluation; the development of computer tools for the use of the model; and the investigation of case-studies with simulated streams of messages for the development of results and the derivation of conclusions.

A General Model

The aim of the general model is to represent three stages of adding data overheads to each originated data message of a message stream. The first stage divides each data message into units of a specific size (in SNA this is the Application Buffer size: AB bits). The resulting units will be of equal size (AB) except for the last unit which would be a fraction of that equal size. Overheads will then be added to each unit before introducing it to a second framing stage.

The second framing stage divides the data units resulting from the first stage, together with the first stage overheads, into new units of a new size (in SNA this is the Request/Response Unit size: RU bits). The resulting units will be of equal size (RU) except for the last new units which will be a fraction of that equal size. More overheads are then added to each new unit before transmitting them through a specific network link.

In the transmission of the new units, together with their overheads, transmission errors may occur; and this would usually cause the retransmission of the units received

in error depending on the error control protocol used (SNA uses SDLC with "GO-Back-N" protocol) [3]. Such retransmission can be viewed as additional data overheads.

The three stage overheads described above have been formulated within a general model; and this formulation is presented in the following.

- Figure 1 represents the first stage framing of a data message $M[i]$ of a stream of N messages; and Table 1 describes the factors associated with the input message stream, the AB framing and the overheads of this stage.

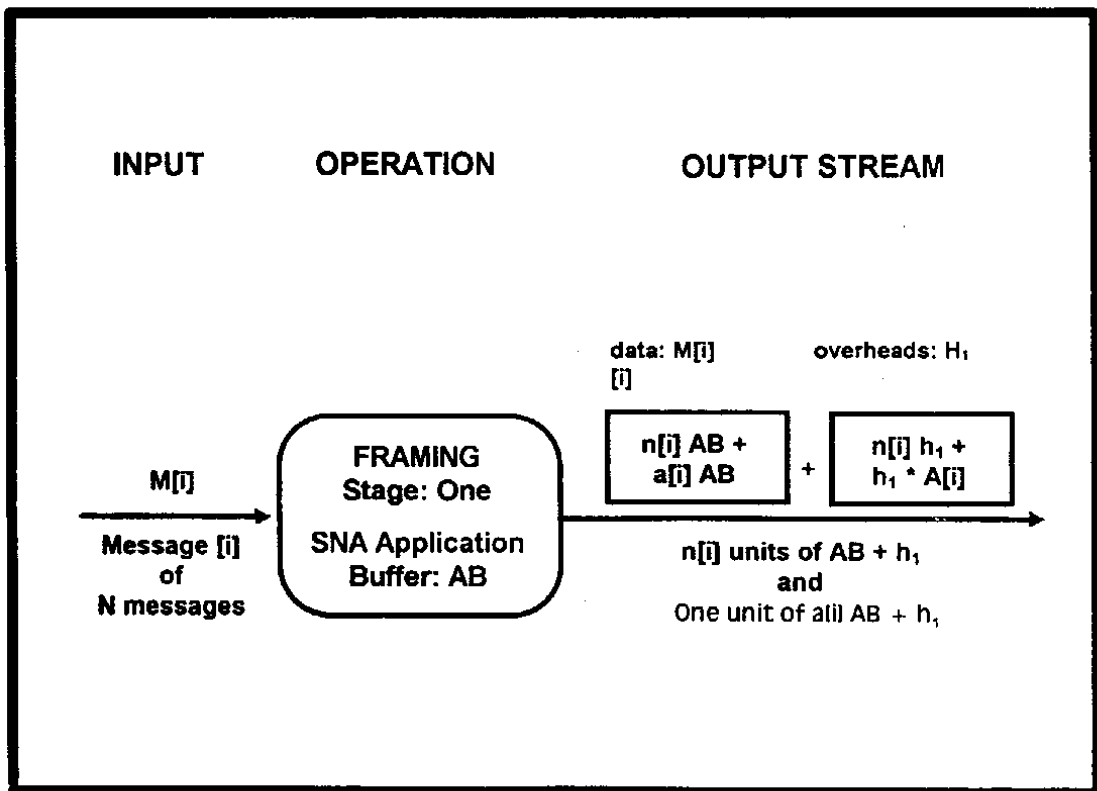

Fig. 1. First stage framing (SNA-AB framing) of a single message.

- Figure 2 represents the second stage framing of the units resulting from the first stage; and Table 2 describes the factors associated with the input stream of this stage, the RU framing, and the overheads.
- Table 3 describes the factors associated with the transmission stream, transmission errors, retransmission, and the overheads.

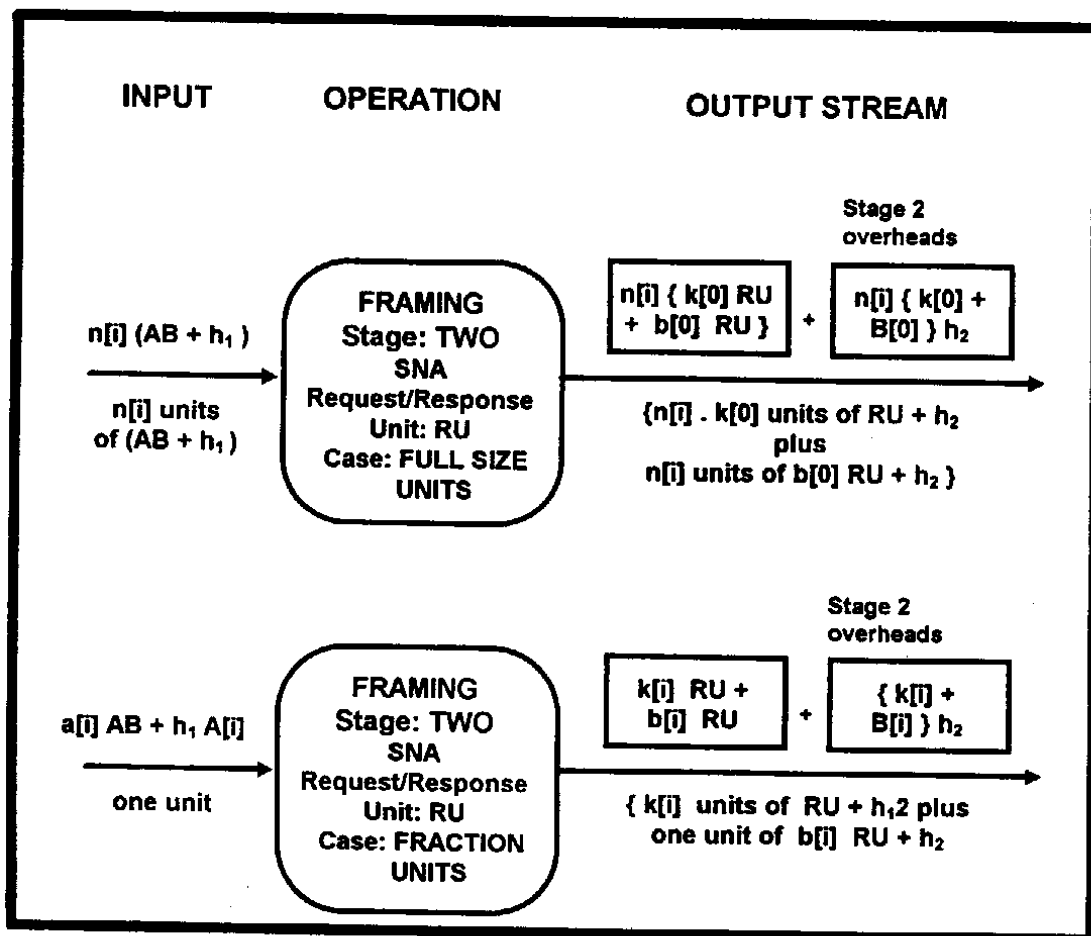

Fig. 2. Second stage framing (SNA-RU framing) of streams resulting from a single message.

- Table 4 describes the overheads ratio that can be used for the evaluation of the overheads considered.

Computer Implementation

For the evaluation of the overheads described above, for various case studies, using the developed model, a computer program, that implements the model has been derived. The program:

- accepts simulated message streams, or practical streams collected from previous experience;

- performs the first and the second stage framing, as well as the transmission stage considering the various corresponding overheads; and
- evaluates the overheads against the various factors considered including: the characteristics of the message stream, the AB size, the RU size, the retransmission protocol used, and the bit error rate.

Figure 3 gives a general flowchart that represents the basic tasks of the developed computer program.

As shown in Table 1, for computing V_1 , $H_1[i]$ for all messages needs to be computed, and this depends on the values of $n[i]$ and $a[i]$. In addition, for computing V_2 of Table 2, $H_2[i]$ for all messages needs to be computed, and this does not only depend on $n[i]$ and $a[i]$, but it also depends on $k[0]$, $b[0]$, $k[i]$, and $b[i]$. Table 5 shows how $H_1[i]$ and $H_2[i]$ can be computed for different values of $n[i]$, $a[i]$, $k[0]$, $b[0]$, $k[i]$, and $b[i]$.

As shown in Table 3, for computing V_3 , $H_3[i]$ for all messages needs to be computed, and this depends on the above mentioned factors, and on the retransmission rules of the data link protocol used. Table 6 shows how $H_3[i]$ can be computed for the case of SDLC with "GO-Back-N" protocol (we consider that the frame in error and the next one will be retransmitted except for the last frame).

Practical Investigations

The practical investigation presented here considers the question of *how the overheads ratio (R) changes* with the change of the values of the main parameters considered including: The *message stream* (messages of random length $M[i]$, where i is a counter for N messages); the size of the first framing stage (AB); the size of the second framing stage (RU); and the probability that a bit is in error (p). This helps in providing *guidelines* for choosing suitable values for AB and RU , so that the *overheads ratio* can be minimized for *given message streams* and expected *transmission errors*. Using this (for our purpose in GULFNET) would improve *network throughput*.

For the investigation described below, the message stream is simulated considering the *message length* to be of *exponential distribution* with an *average message length* that can be given as an *input parameter* For the simulation of the stream the work given in [4] has been used.

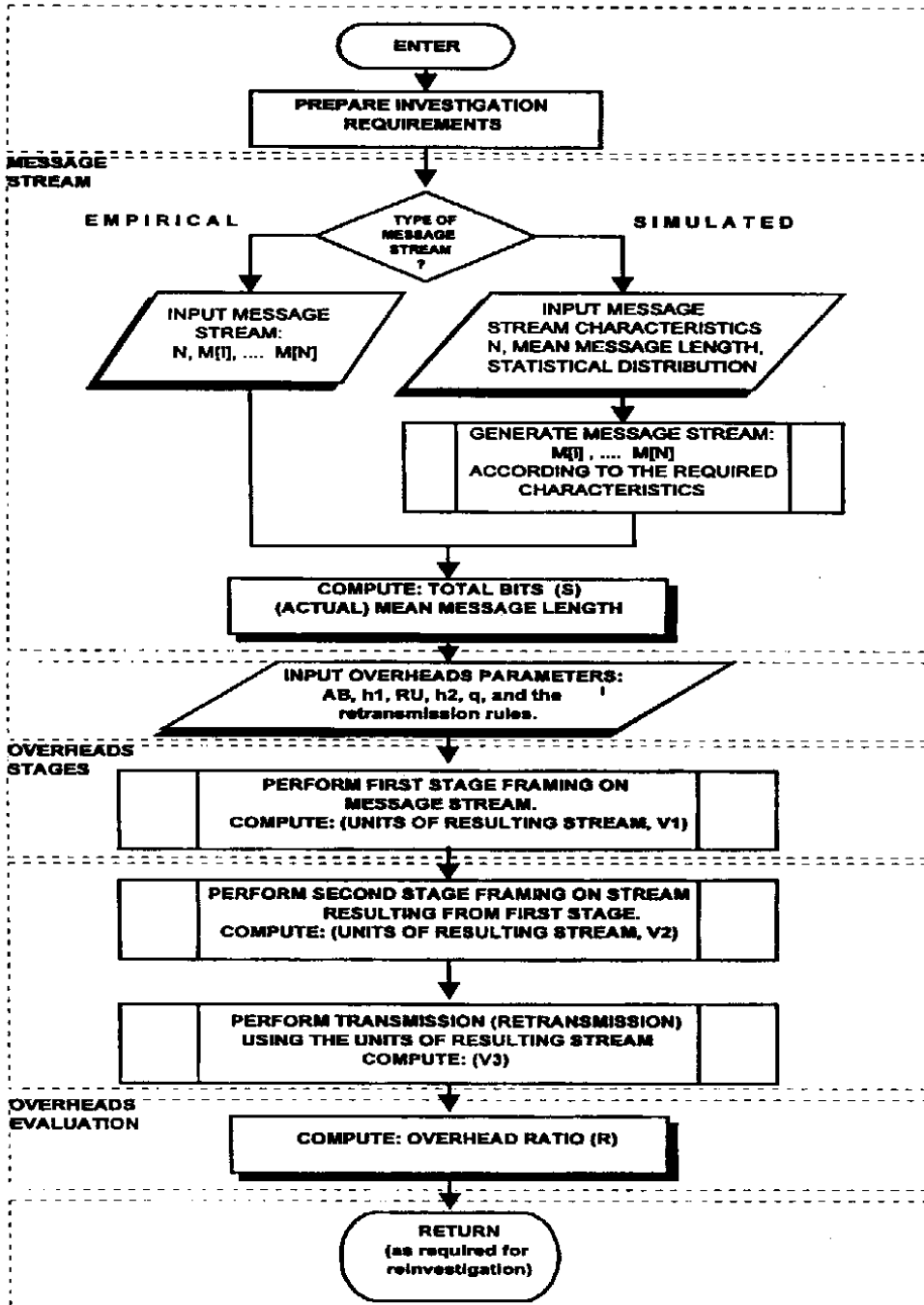

Fig. 3. A general flowchart representing the basic tasks of the developed computer program that implements the model.

Table 1. Basic issues and factors associated with the analysis of overheads resulting from AB framing

ISSUE	FACTOR	DESCRIPTION
Input stream	N	Number of messages
	i	Message counter
	M[i]	Length of message [i] (bits)
	S	Total number of bits in the message stream. $S = \sum_{i=1}^N M[i]$ (bits)
Framing (application buffer)	AB	Application buffer size (bits)
	Dividing: M[i]	$\frac{M[i]}{AB} = n[i] + a[i]$
	n[i]	Number of complete AB units in M[i]: n[i] is an integer.
	a[i]	The fraction of AB in M[i]: $0 < a[i] < 1$
	A[i]	$A[i] = 1$ for $a[i] > 0$ $A[i] = 0$ for $a[i] = 0$
Overheads	h ₁	Length of overheads added to each unit of size AB and of a fraction of AB. (bits)
	H ₁ [i]	Length of first stage overheads for M[i]. (bits) $H_1 [i] = \{ n[i] + A[i] \} h_1$
	V ₁	Total overheads for the message stream due to the first stage framing. (bits) $V_1 = \sum_{i=1}^N H_1 [i]$

The results obtained, from the evaluation of the overheads ratio, **R** for different values of **AB**, **RU**, **p**, and the average message length of the data stream \overline{M} are given in the following Figures:

- Figure 4 shows the change of **R** versus the change of **RU** for different values of **AB**, assuming one given value for **p** and another for \overline{M} .

Table 2. Basic issues and factors associated with the analysis of overheads resulting from RU framing

ISSUE	FACTOR	DESCRIPTION
Input stream	STREAM RESULTING FROM $M[i]$	$M[i] + H_2[i] = n[i] (AB + h_1) + a[i] AB + h_1 A[i]$
	FULL SIZE UNITS	SIZE = $AB + h_1$ (bits) Number of full size units in $M[i]$ is: $n[i]$
	FRACTION UNITS	SIZE = $a[i] AB + h_1 A[i]$ (bits) One fraction unit in $M[i]$, if $a[i] > 0$
Framing (Request/Response unit)	RU	Request/Response unit size (bits)
	DIVIDING: $AB + h_1$	$\frac{AB + h_1}{RU} = k[0] +$
	DIVIDING: $a[i] AB + h_1 A[i]$	$\frac{a[i] AB + h_1 A[i]}{RU} = k[i] + b[i]$
	$k[0]$	Number of complete RUs in a fixed size input unit.
	$b[0]$	The fraction of RU in a fixed size input unit.
	$B[0]$	$B[0] = 1$ for $b[0] > 0$ $B[0] = 0$ for $b[0] > 0$
	$k[i]$	Number of complete RUs in the fixed variable size input unit i .
	$b[i]$	The fraction of RU in the fixed size variable input unit i .
	$B[i]$	$B[i] = 1$ for $b[i] > 0$ $B[i] = 0$ for $b[i] > 0$
Overheads	h_2	Length of overheads added to each complete RU or fraction unit of RU. (bits)
	$H_2[i]$	Length of overheads for the input stream resulting from $M[i]$. (bits) $H_2[i] = n[i] \{ k[0] + B[0] \}$ $h_2 + \{ k[i] + B[i] \} h_2$
	V_2	Total overheads for the message stream. (bits) $V_2 = \sum_{i=1}^N H_2[i]$

- Figure 5 is similar to Figure 4, but for another value of \overline{M} . This illustrates the effect of changing the value of \overline{M} on the other factors.

Table 3. Basic issues and factors associated with the analysis of overheads resulting from retransmissions caused by transmission errors

ISSUE	FACTOR	DESCRIPTION
Input stream	STREAM RESULTING FROM M[i]	$M[i] + H_1[i] + H_2[i] =$ (bits) $\{ n[i] k[0] + k[i] \} (RU + h_2) +$ $n[i] \{ b[0] RU + B[0] h_2 \} + b[i] RU + B[i] h_2$
	FULL SIZE UNITS	$SIZE = RU + h_2$ (bits) Number of full size units in M[i] is: $n[i] k[0] + k[i]$
	SMALLER FIXED SIZE UNITS	$SIZE = b[0] RU + h_2$ Number of smaller fixed size units is: $n[i]$
	VARIABLE SIZE UNITS	$SIZE = b[i] RU + h_2$ One variable size unit in M[i] if $b[i] > 0$
Transmission errors	q	The probability that a bit is correct.
	p	The probability that a bit is incorrect. $p = 1 - q$
	Q["size"]	The probability that a frame of size "size" is correct. $Q = (q)^{size} = (1 - p)^{size}$
	P["size"]	The probability that a frame of size "size" is incorrect. $P = 1 - Q = 1 - (1 - p)^{size}$
Retransmission overheads	$h_{3,1}$	Overheads resulting from the retransmission of a full size unit: $RU + h_2$ $P [RU + h_2] (RU + h_2)$
	$h_{3,2}$	Overheads resulting from the retransmission of a smaller fixed size units: $b[0] RU + B[0] h_2$ $P [b[0] RU + B[0] h_2] \{ b[0] RU + B[0] h_2 \}$
	$h_{3,3}$	Overheads resulting from the retransmission of a variable size units: $b[i] RU + B[i] h_2$. It exist if $b[i] > 0$. $P [b[i] RU + B[i] h_2] \{ b[i] RU + B[i] h_2 \}$
	$H_3[i]$	Retransmission overheads for M[i]. It depends on $h_{3,1}$, $h_{3,2}$, $h_{3,3}$, and the data link protocol used. (e.g. Synchronous Data Link Control: SDLC with "GO-Back-N" or with "Selective Repeat".
	DATA LINK PROTOCOL	SDLC is used by IBM-SNA. It is based on ARQ principles (Automatic Repeat Request). It has different types. In SDLC with "GO-Back-N", each frame received in error is retransmitted with the (N) most recent frames. In SDLC with "Selective Repeat", only the frame received in error is retransmitted. $H_3[i]$ can be computed according to the above. (See Table 10.6)
	V_3	Total overheads resulting from retransmission. (bits) $V_3 = \sum_{i=1}^N H_3[i]$

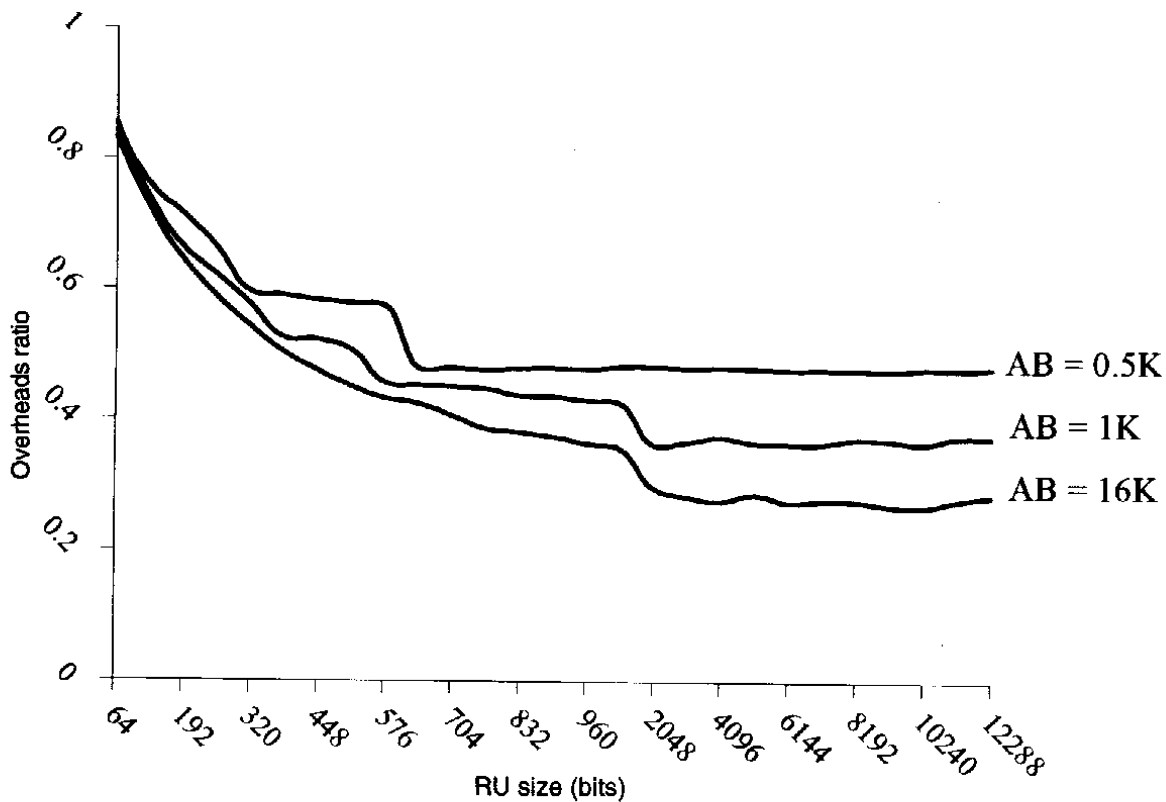

Fig. 4. The overheads ratio versus the RU size for different values of AB. (Mean = 1K, P=1E-5).

Table 4. The overheads ratio for the three stages

ISSUE	FACTOR	DESCRIPTION
Measuring the relative level of overheads	GENERAL OVERHEADS RATIO	Measures the proportion of overheads: $\frac{\text{OVERHEADS}}{\text{DATA} + \text{OVERHEADS}}$
	R	The overheads ratio of the three stages considered. $R = \frac{V_1 + V_2 + V_3}{S + V_1 + V_2 + V_3}$

- Figure 6 is similar to Figure 5, but for another value of p. This illustrates the effect of changing the value of p on the other factors.

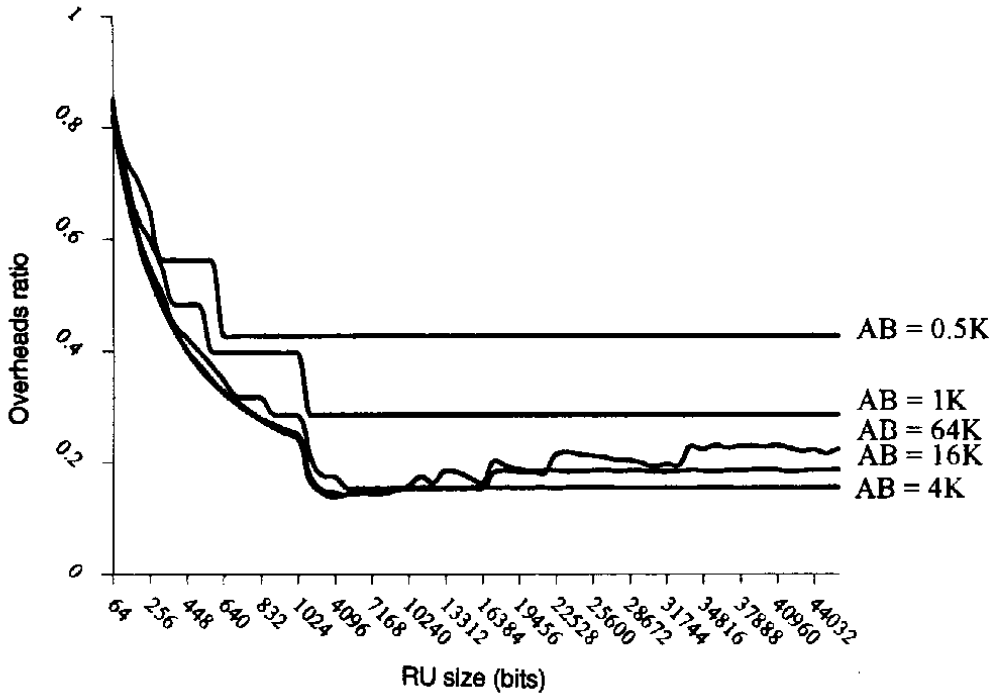

Fig. 5. The overheads ratio versus the RU size for different values of AB. (Mean = 16K, P = 1E-5).

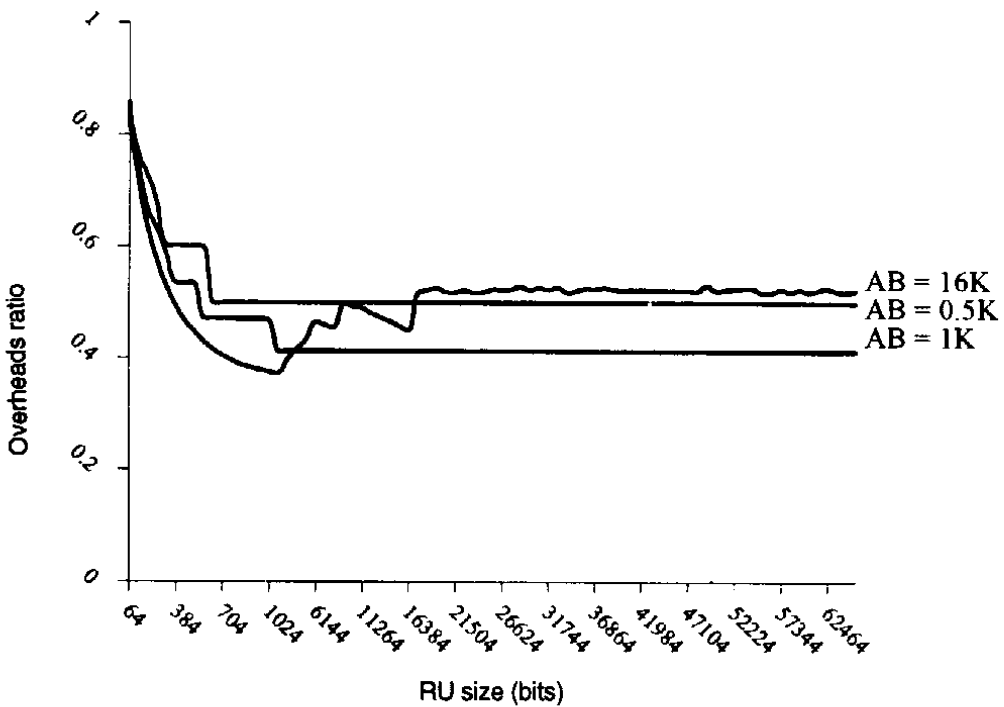

Fig. 6. The overheads ratio versus the RU size for different values of AB. (Mean = 16K, P = 1E-4).

Table 5. The first stage framing and the second stage framing overheads, $H_1[i]$ and $H_2[i]$, for different possible cases of message length versus framing sizes

CASE SPECIFICATIONS						$H_1[i]$ (bits)	$H_2[i]$ (bits)					
$n[i]$	$a[i]$	$k[0]$	$b[0]$	$k[i]$	$b[i]$							
0	#0	0	0	0	#0	h_1	h_2					
				#0	0		$k[i] h_2$					
				#0	#0		$\{ k[i] + B[i] \} h_2$					
#0	0	0	#0	0	0	$n[i] h_1$	$n[i] h_2$					
							#0	0	$n[i] k[0] h_2$			
							#0	#0	$n[i] \{ k[0] + B[0] \} h_2$			
	#0	0	#0	0	0	#0	$\{ n[i] + 1 \} h_1$	$\{ n[i] + 1 \} h_2$				
								#0	0	#0	0	$\{ n[i] k[0] + 1 \} h_2$
										#0	#0	$\{ n[i] k[0] + k[i] \} h_2$
		#0	0	#0	0	#0		#0	$\{ n[i] k[0] + k[i] + 1 \} h_2$			
									#0	0	$\{ n[i] k[0] + n[i] + 1 \} h_2$	
			#0	0	#0	0		#0	#0	$\{ n[i] k[0] + n[i] + k[i] \} h_2$		
										#0	#0	$\{ n[i] k[0] + n[i] + k[i] + 1 \} h_2$

Figure 4 represents a case of relatively small messages ($\overline{M} = 1$ k bits), and limited BER ($p = 10^{-5}$). The Figure shows that for smaller values of RU , the overheads ratio R is high for various values of AB (smaller, equal, and larger than \overline{M}). It illustrates that minimum overheads can be achieved when RU is greater than a certain limit. This limit changes according to the value of AB .

Figure 5 represents a case of larger messages ($\overline{M} = 16$ k bits), and limited BER ($p = 10^{-5}$). As in Figure 4, smaller values of RU cause high R , and minimum R is achieved when RU increases beyond a certain limit. Unlike the case of Figure 4, it is noticed that when AB increases (larger than \overline{M}) minimum R is achieved at a single value of RU instead of large scale of values.

Table 6. The retransmission overheads of a message, H3[i], for the different possible cases assuming SDLC "GO-Back-N" (the frame in error and the next one will be retransmitted except for the last frame)

CASE SPECIFICATIONS						RETRANSMISSION OVERHEADS H ₃ [i] SDLC "GO-Back-N" (retransmitting the frame in error, together with the next, except for the last frame) (bits)
n[i]	a[i]	k[0]	b[0]	k[i]	b[i]	
0	#0	0	0	0	#0	{ b[i] RU + h ₂ } P["b[i] RU + h ₂ "]
		0	0	#0	0	{ 2k[i] - 1 } (RU + h ₂) P["RU + h ₂ "]
		0	0	#0	#0	{ 2k[i] - 1 } (RU + h ₂) P["RU + h ₂ "] + { (RU + h ₂) + { b[i] RU + h ₂ } } P["RU + h ₂ "] + { b[i] RU + h ₂ } P["b[i] RU + h ₂ "]
#0	0	0	#0	0	0	{ 2n[i] - 1 } { b[0] RU + h ₂ } P["b[0] RU + h ₂ "]
		#0	0	0	0	{ 2 { n[i] * k[0] } - 1 } (RU + h ₂) P["RU + h ₂ "]
		#0	#0	0	0	2n[i] { k[0] - 1 } (RU + h ₂) P["RU + h ₂ "] + n[i] { (RU + h ₂) + { b[0] RU + h ₂ } } P["RU + h ₂ "] + { n[i] - 1 } { (RU + h ₂) + { b[0] RU + h ₂ } } P["b[0] RU + h ₂ "] + { b[0] RU + h ₂ } P["b[0] RU + h ₂ "]
	#0	0	#0	0	#0	2 { n[i] - 1 } { b[0] RU + h ₂ } P["b[0] RU + h ₂ "] + { { b[0] RU + h ₂ } + { b[i] RU + h ₂ } } P["b[0] RU + h ₂ "] + { b[i] RU + h ₂ } P["b[i] RU + h ₂ "]
		#0	0	0	#0	2 { n[i] k[0] - 1 } (RU + h ₂) P["RU + h ₂ "] + { (RU + h ₂) + { b[i] RU + h ₂ } } P["RU + h ₂ "] + { b[i] RU + h ₂ } P["b[i] RU + h ₂ "]
		#0	0	#0	0	2 { n[i] k[0] + k[i] - 1 } (RU + h ₂) P["RU + h ₂ "]
		#0	0	#0	#0	2 { n[i] k[0] + k[i] - 1 } (RU + h ₂) P["RU + h ₂ "] + { (RU + h ₂) + { b[i] RU + h ₂ } } P["RU + h ₂ "] + { b[i] RU + h ₂ } P["b[i] RU + h ₂ "]
		#0	#0	0	#0	2 { n[i] { k[0] - 1 } } (RU + h ₂) P["RU + h ₂ "] + n[i] { (RU + h ₂) + { b[0] RU + h ₂ } } P["RU + h ₂ "] + { n[i] - 1 } { (RU + h ₂) + { b[0] RU + h ₂ } } P["b[0] RU + h ₂ "] + { { b[0] RU + h ₂ } + { b[i] RU + h ₂ } } P["b[0] RU + h ₂ "] + { b[i] RU + h ₂ } P["b[i] RU + h ₂ "]
		#0	#0	#0	0	2 n[i] { k[0] - 1 } (RU + h ₂) P["RU + h ₂ "] + n[i] { (RU + h ₂) + { b[0] RU + h ₂ } } P["RU + h ₂ "] + n[i] { (RU + h ₂) + { b[0] RU + h ₂ } } P["b[0] RU + h ₂ "] + 2 { k[i] - 1 } (RU + h ₂) P["RU + h ₂ "] + (RU + h ₂) P["RU + h ₂ "]
		#0	#0	#0	#0	2 n[i] { k[0] - 1 } (RU + h ₂) P["RU + h ₂ "] + n[i] { (RU + h ₂) + { b[0] RU + h ₂ } } P["RU + h ₂ "] + n[i] { (RU + h ₂) + { b[0] RU + h ₂ } } P["b[0] RU + h ₂ "] + 2 { k[i] - 1 } (RU + h ₂) P["RU + h ₂ "] + { (RU + h ₂) + { b[i] RU + h ₂ } } P["RU + h ₂ "] + { b[i] RU + h ₂ } P["b[i] RU + h ₂ "]

Figure 6 represents a case of larger messages ($\bar{M} = 16$ k bits), and higher BER ($p = 10^{-4}$). The Figure shows that for higher BER smaller values of RU provide minimum R.

The above figures illustrate how the overheads can be evaluated under different conditions. The developed program allows future evaluations for given empirical data for both; message streams and BER. This would help deriving AB and RU values that minimize the overheads ratio and consequently maximize throughput.

Conclusions

The work presented in this paper has analyzed the data overheads problem for a message stream considering a two-stage framing together with a data link (retransmission) protocol: a typical case of IBM-SNA with SDLC (used in GULFNET). A computer program for the implementation of the analysis have been developed, and used for a given case study. The work illustrates how the various factors involved can be balanced, under different circumstances, so that overheads can be minimized. The general approach used would be useful, to researchers in the field, in the evaluation of data overheads for other network architectures, with different framing and different control of transmission errors.

References

- [1] Majithia, J.C. and Bhar, R. "Analysis of Overheads in Packet Switched Data Networks." *Proc., IEEE*, 121, No.11 (Nov. 1974), and "Optimum Packet Size in a Packet Switched Data Networks." *Electronic.*" 10, No. 16 (May 1974).
- [2] Schwartz, M. *Telecommunication Networks: Protocols Modelling and Analysis*. Addison-Wesley Publishing Co., 1987.
- [3] Martin, J. *Data Communication Technology*. Prentice Hall, 1987.
- [4] Bakry, S.H. and Shatila, M. "Pascal Functions for the Generation of Random Numbers." *International Journal of Computer and Mathematics with Applications.*" Pergamon Press, 15, No.11 (July 1988), 969-973.

تقويم حواشي لمراحل

متعددة من الهيكلية وإعادة الإرسال مع التركيز على نظام IBM - SNA

عماد الصغير* و عبدالله الضلعان و سعد الحاج بكري**

* مدينة الملك عبدالعزيز للعلوم والتقنية ، ** كلية الهندسة، جامعة الملك سعود

ملخص البحث . يقدم هذا البحث وسائل رياضية وحاسوبية لتقويم حواشي المعطيات في مجموعات من الرسائل تخضع لمرحلتين من الهيكلية، ولقاعدة إعادة الإرسال من أجل تصحيح الأخطاء عند الحاجة. وينطبق ذلك على نظام : IBM - SNA ، الذي يستخدم قاعدة إعادة الإرسال : SDLC . ويعطى البحث تطبيقاً يوضح استخدام هذه الوسائل، ويبين العوامل المختلفة التي تؤثر على الحواشي، والتي يمكن تحليلها للوصول بالحواشي إلى الحد الأدنى ، مما يرفع إنتاجية الإرسال إلى الحد الأعلى. و تفيد طريقة التقويم المستخدمة في هذا البحث الدراسات المستقبلية لحواشي المعطيات في حالات هيكلية وإعادة إرسال أخرى.