

## **A Study of Formation Damage under Simulated Reservoir Conditions**

**Adnan Omar**

*Petroleum Engineering Department, College of Engineering,  
King Saud University, P. O. Box 800, Riyadh 11421, Saudi Arabia*

**Abstract.** Among the various formation damage aspects, a natural phenomenon is experienced which is caused by the incompatibility between connate and injected brines during waterflooding. The consequence of this damage is a substantial drop in the permeability of sandstone rocks, ultimately leading to a drop in oil recovery. Formation damage due to this mechanism has been well established at laboratory conditions and was found to be the result of swelling and/or migration of fines within the cores.

The drop in the recovery and the relative permeability ratio, caused by the gradual decrease in the concentration of displacing brine were measured at different temperatures and pressures for three different types of sandstone cores. Formation damage was found to occur at all temperatures and pressures studied during the tests. However, an increase in temperature reduced the drop in both the recovery and the relative permeability ratio appreciably, the maximum change in recovery dropped from 34% at room temperature to 21% at 90°C for the sandstone cores under investigation. Overburden pressure had a minimal effect on the extent of formation damage.

### **1. Introduction**

When the decision was taken to shift from aquifer water to sea water in waterflooding operations in Saudi Arabia the question of formation damage was aroused. Most Saudi reservoirs have high saline connate brines (20-30% NaCl) and hence are susceptible to formation damage whenever relatively fresh water invades them. A loss in permeability of a particular reservoir rock affects both the sweep efficiency of a waterflooding operation and the residual oil saturation. Several cases of formation damage, caused by the use of relatively fresh brine during water flooding, were reported in the literature [1-7]. The main cause of the damage was [3]:

- 1- Swelling of indigenous clays which constricts the pores available for flow.
- 2- Dispersion and migration of indigenous, non swelling particles, rearrangement of the particles during fluid flow and the consequent plugging of the pore system.

- 3- A combination of swelling and dispersion which promotes loosening and mobilizing of fines and particles.

Several methods were developed that can predict formation damage characteristics, the most successful of which is displacement runs using cores obtained from oil reservoirs and incompatible brines. Almost all such runs were carried out at normal laboratory conditions [5-10], but in order to relate these measurements to reservoir conditions the effect of temperature and overburden pressure has to be determined.

Several investigators have studied the effect of temperature on residual saturations and relative permeabilities to oil and water [11-16]. The net result of these studies was that temperature reduces residual oil saturation and increases irreducible water saturation. The relative permeability to oil was found to increase with temperature while the relative permeability to water decreases with temperature. At higher temperatures the fractional wettability to water increases with a resulting increase in oil recovery. A balanced decrease in residual saturations and relative permeability to oil and water was observed to accompany any increase in the overburden pressure within the elastic range of compressibility of the sandstone cores used [17-19].

In this work three types of sandstone cores, namely: Berea, cores obtained from Aramco production area in the eastern part of Saudi Arabia, and cores obtained from Alkhafji producing area in the north-eastern part of Saudi Arabia, were analyzed to determine the percentage and nature of the clay they contain and hence obtain an overview of their susceptibility to formation damage. They were used in displacement runs at different temperatures and overburden pressures. In each run the core under consideration was saturated with a 25% wt. NaCl aqueous brine and then intermittently displaced with oil and brines of equal and less concentrations till fresh water was used. Every displacement test was carried out at constant temperature and pressure. Relative permeability curves were obtained using JBN method [20] (Appendix 1).

The variation in two parameters was followed throughout the displacement tests, these parameters being the percentage recovery and the relative permeability ratio. The percentage recovery (%  $R_x$ ) was calculated at any concentration of the displacing brine  $x$  from the equation:

$$\%R_x = \frac{1 - S_{orx} - S_{wir}}{1 - S_{wir}} \times 100$$

where,  $S_{orx}$  and  $S_{wir}$  are the residual oil saturation and the irreducible water saturation respectively. The relative permeability ratios ( $k_{rox}/k_{rwx}$ ) were calculated using the relative permeabilities determined at the residual saturations.

The percentage change in the recovery at any concentration (%  $C.R_x$ ) was determined using the following equation:

$$\%C.R_x = \frac{S_{orx} - S_{or25} + S_{wir} S_{or25} - S_{orx} S_{wi25}}{(1 - S_{wir})(1 - S_{or25} - S_{wi25})} \times 100$$

where the subscript 25 denotes the initial saturating concentration which was 25% wt. NaCl in all the experiments. The corresponding change in the relative permeability ratio ( $k_{rox}/k_{rwx}$ ) was calculated using the following equation:

$$\Delta \left( \frac{k_{rox}}{k_{rwx}} \right) = \frac{k_{rox} k_{rw25} - k_{ro25} k_{rwx}}{k_{rwx} k_{ro25}}$$

The percentage recovery ratio (%R.R<sub>x</sub>) and the percentage relative permeability ratio (%k<sub>rx</sub>) can thus be defined as:

$$\%R.R_x = 100 - \%C.R_x$$

and

$$\%k_{rx} = 100 - \Delta (k_{ro}/k_{rwx}) \times 100$$

## 2. Materials and Apparatus

### 2.1. The Cores

Three sets of core samples were obtained for use in the experimental work. Berea sandstone, Alkhafji sandstone and Aramco sandstone cores. The latter two were obtained from producing depths in oil fields and constitute the subject of the present investigation, whereas Berea sandstone cores were used for the sake of comparing and relating obtained results to published research work.

Samples of the cores were granulated and sieved. The finer parts of the samples were soaked in water, the decanted colloidal solution was then allowed to dry in an oven at 45°C. The granulated sample was then analyzed for its mineral content using x-ray diffraction and the result is reported in Table 1-A. The fines sample obtained from the drying of the colloidal solution was divided into 4 parts.

Table 1-A. Mineralogical composition of the sandstone cores

Type	Quartz % wt	Feldspar % wt	Other minerals % wt	Clays % wt
Berea	75	10	5*	10
Alkhafji	92	2	1	5
Aramco	85	3	4**	8

\* Mainly dolomite

\*\* Mainly pyrite

The first part was soaked in ethylene glycol, the second was heated to 550°C, the third to 900°C and the fourth was left untreated. The four samples were then placed on slides, which were then analyzed with an x-ray diffractometer. The relative amounts of clay families were then computed using Scaf's method and are reported in Table 1-B.

Table 1-B. % Relative abundance of clay families

Type	Kaolinite	Chlorite	Illite	Montmorillonite
Berea	63	9	25	traces
Alkhafji	69	35	-	-
Aramco	40	27	17	6

Samples of fines obtained from the sieving were soaked in water. The colloidal solution obtained was then saturated with  $\text{NH}_4\text{Cl}$ , and was left to react for 10 days. The remainder of  $\text{NH}_4\text{Cl}$  was washed with methanol and then it was steam distilled in a micro-distillation apparatus to determine the amount of  $\text{NH}_4^+$  adsorbed. The result is given in the last column of Table 1-C.

Table 1-C. Base exchange capacity of the untreated clays

Type	Cation milliequivalent/100 gms			Net base exchange capacity $\text{NH}_4^+$ distillation
	Mg <sup>++</sup>	Ca <sup>++</sup>	Na <sup>+</sup>	
Berea	4	3	12	17
Alkhafji	2	5	-	7
Aramco	16	5	8	26

An amount of the solution containing the fines obtained through granulating, soaking and decanting was used to measure the concentration of exchangeable metallic elements using an atomic absorption spectrophotometer (A. A. S.). The concentration of the different elements can be found in Table 1-C.

## 2.2. Experimental Apparatus

Figure 1 shows the schematic diagram of the experimental equipment. The equipment is composed of three parts: the Jefri constant rate pump, the oven assembly and the control panel. The set up is an assembly of five basic operational systems: flow, overburden pressure, heating, back-pressure and transducer. The systems are designed to control and monitor the conditions present in the core holder and the core samples.

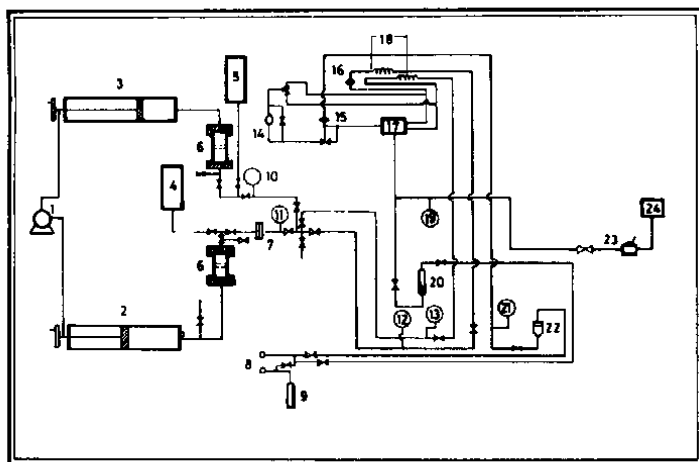

- |  |  |
|--|--|
| 1. Jefri pump drive                      | 13. Brine upstream pressure gauge      |
| 2. Jefri pump brine reservoir and piston | 14. Pressure transducer                |
| 3. Jefri pump oil reservoir and piston   | 15. Back pressure regulator            |
| 4. Brine reservoir                       | 16. Oil filter                         |
| 5. Oil reservoir                         | 17. Core holder                        |
| 6. Floating piston cylinders             | 18. Heating coils                      |
| 7. Brine filter                          | 19. Overburden pressure gauge          |
| 8. Pressure control system               | 20. Gas balance cylinder               |
| 9. Nitrogen cylinder                     | 21. Back pressure gauge                |
| 10. Oil pressure gauge                   | 22. Back pressure regulator multiplier |
| 11. Brine pressure gauge                 | 23. Hand pump                          |
| 12. Oil upstream pressure gauge          | 24. Water supply                       |

Fig. 1. Schematic diagram of experimental apparatus

### 3. Experimental Procedure

The effect of temperature and pressure on formation damage was studied using ten Berea sandstone cores denoted B1 to B10, ten Alkhatji sandstone cores denoted K1 to K10, and ten Aramco sandstone cores denoted A1 to A10.

The cores were cut, dried at 160°F for 24 hours vacuumed for another 24 hours and then saturated with 25% wt. NaCl aqueous solution for 16 hours while under vacuum.

All the cores were measured for their diameters and lengths. Their porosities were calculated using the dry and saturated weights. The initial permeabilities of the cores were established by displacing the cores with a solution of equal concentration as the saturating solution. The physical properties of the cores are compiled in Table 2.

Table 2. Physical properties of the sandstone core samples

Core No.	Diameter cm	Length cm	Dry weight g	Porosity %	Initial permeability %
B1	3.81	8.97	199.24	19.08	309.8
B2	3.81	8.91	189.71	19.41	320.2
B3	3.81	9.14	204.16	20.09	300.9
B4	3.81	9.75	214.24	21.41	300.8
B5	3.81	9.24	208.81	19.06	311.6
B6	3.81	8.25	186.81	20.41	307.7
B7	3.81	8.61	184.41	20.41	304.5
B8	3.81	8.77	186.90	19.20	311.4
B9	3.81	8.91	184.90	19.33	316.6
B10	3.81	9.20	204.41	20.11	320.7
K1	3.78	8.66	181.41	16.62	352.4
K2	3.83	7.82	161.21	16.51	355.4
K3	3.77	8.51	179.41	16.77	348.8
K4	3.81	5.75	128.91	15.81	366.7
K5	3.81	5.88	130.34	17.22	371.7
K6	3.75	6.21	152.41	16.82	377.4
K7	3.76	7.23	177.81	17.21	392.4
K8	3.76	8.24	186.91	15.82	381.4
K9	3.77	8.11	184.90	16.33	375.4
K10	3.78	6.81	168.41	16.21	378.4
A1	3.82	7.81	161.42	18.81	120.4
A2	3.81	7.79	160.21	19.51	98.8
A3	3.77	7.92	168.41	20.41	110.6
A4	3.77	7.77	160.21	22.11	121.4
A5	3.77	7.78	161.08	21.11	122.3
A6	3.78	7.91	168.71	22.41	125.3
A7	3.91	7.83	164.41	18.60	123.3
A8	3.92	7.76	160.24	19.41	120.6
A9	3.78	7.81	163.32	19.31	95.4
A10	3.76	7.88	164.41	18.51	96.4

The cores were then mounted on the core holder each at a time and were displaced with oil and solutions of decreasing concentration alternately till fresh water was used. The concentration of the displacing aqueous solutions were 25, 20, 15, 5 and 0% wt. NaCl.

The flow rate was determined by measuring the amount of effluents at given intervals of time, and the following properties of effluents were measured:

- 1- specific gravity,
- 2- resistivity,
- 3- pH value, and
- 4- interfacial tension.

For any particular core the temperature and overburden pressure were kept constant, but they were allowed to vary from one core to the other according to Table 3. It should be noted that the following limitations were imposed by the experimental setup and the nature of the cores:

- 1- At 4000 psig the Aramco sandstone cores split laterally (along the principal axis), however, measurement of stress-strain relationship for the cores showed that their bulk modulus remained constant up to 3000 psig (*i.e.* their behaviour was in the elastic range at 3000 psig). Subsequent pressures were then confined to this pressure.
- 2- Temperature measurements were confined to 90°C because at higher temperatures (*e.g.* 100°C) two phases may form in the heating coil which leads to improper flow control. Other considerations for choosing 90°C as a maximum temperature were ease of handling and elimination of the possibility of any damage to the core sleeves.

Table 3. Experimental procedure for establishing the effect of formation damage on relative permeability at different temperatures and overburden pressures

Core No. *	Temperature, °C	Pressure, psig
1	30	500
2	30	1000
3	30	2000
4	30	3000
5	50	1000
6	70	1000
7	90	1000
8	90	500
9	90	2000
10	90	3000

\*The three sets of cores: Berea, Alkhalji and Aramco were treated alike, hence the cores number i are B<sub>i</sub>, K<sub>i</sub>, and A<sub>i</sub>.

#### 4. Results and Discussion

Figures 2 - 11 show the variation of the percentage change in recovery and the relative permeability ratio with temperature and pressure. The overburden pressure has a small effect on percentage change in recovery and the relative permeability

ratio at either room temperature (30°C) or elevated temperature (90°C). For this reason, only the average recovery ratio and the relative permeability ratio are plotted in Figs. 2, 3, 10 and 11.

A rise in temperature, on the other hand, was observed to increase the oil recovery ratio. This improved oil recovery for Saudi cores under investigation is apparent from Figs 4, 6 and 8 showing a maximum recovery drop of 35% at 30°C against 21% at 90°C for displacements using fresh water as compared to displacements with connate water containing 25% wt. NaCl.

The increase in oil recovery ratio is due to the relatively higher values of both  $k_{ro}$  and  $k_{rw}$  as indicated in the relative permeability curves (Figs 5,7 and 9). Temperature decreases oil viscosity and reduces the water-wetting to oil-wetting change tendency by increasing the relative mobility of oil.

Another reason for the better relative permeabilities is that temperature usually improves the capillary number saturation relation and reduces partially the effective changes due to formation damage.

One of the results of formation damage is obviously an increase in  $S_{or}$  caused by two phenomena:

- 1- When saline brines interact with crude, fatty acids in the crude react with both the hydroxyl ions in water and the  $Na^+$  ions to form soap. When the salinity is relatively high this soap remains dissolved in the oil phase but when relatively fresh water is used, the soap dissolves in water. Oil is known to have a relatively higher solubility in soap-water solutions than in fresh water and, as a result of this  $S_{or}$  increase, the relative permeability to oil drops.
- 2- The other cause for the increase in  $S_{or}$  is the existence of polar compounds in the investigated oil used. It is known that the pore surface of the cores is generally positively charged. The existence of an ionizable solution between the polar compounds in the crude oil and the pore wall usually retards the diffusion process of these compounds towards the pore wall. This situation changes when fresh water is injected and the rate of mass transfer of these compounds towards the pore walls increases which leads to an increase in  $S_{or}$ .

The most important reason for the observed increase in the recovery ratio is that at high temperature the solubility of the compounds that are partially responsible for the dissolution of some of the oil into the connate water increases, the result being a higher connate water viscosity and a reduced mobility of the oil, thus reducing the effect of relatively fresh water. The rise in temperature also reduces the change in relative permeability ratio. This is due largely to the lowering of the oil viscosity which overshadows the decrease in relative permeability ratio due to the change in the brine concentration.

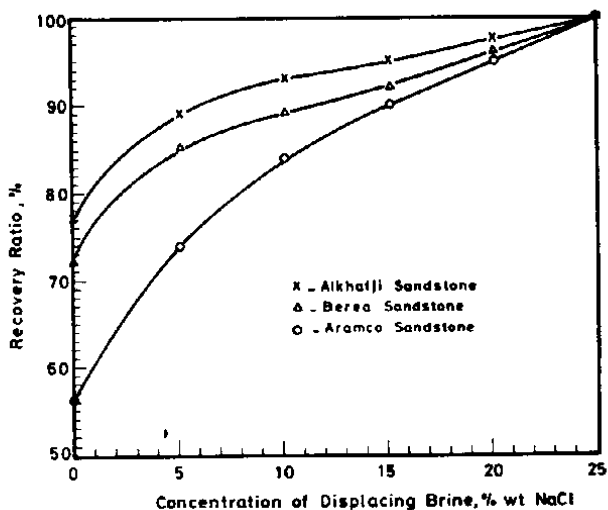

Fig. 2. Average variation of recovery ratio with concentration at 30°C

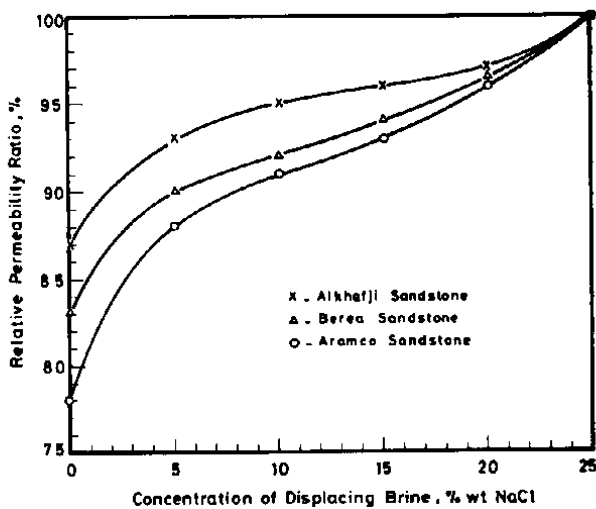

Fig. 3. Average variation of relative permeability ratio with concentration at 30°C

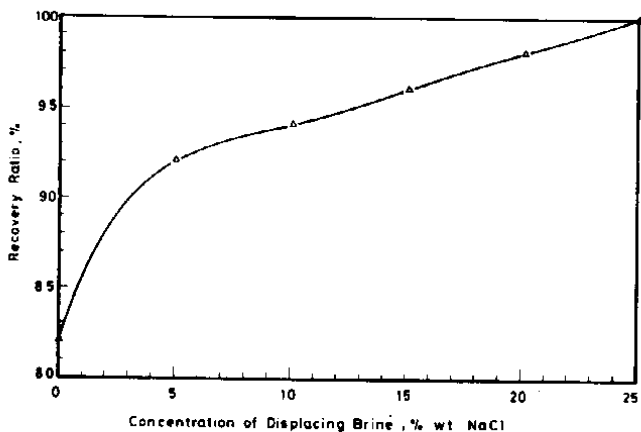

Fig. 4. Average variation of recovery ratio with concentration at different temperatures and 1000 psig pressure, Berea sandstone cores

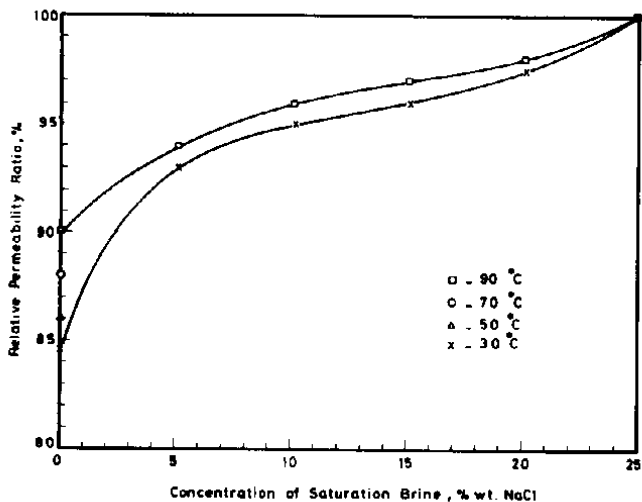

Fig. 5. Variation of relative permeability ratio with concentration at different temperatures and 1000 psig pressure, Berea sandstone cores

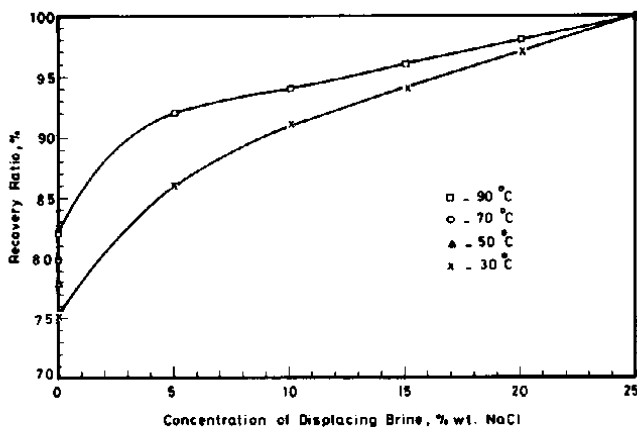

Fig. 6. Variation of recovery ratio with concentration at different temperatures and 1000 psig pressure, Alkhalji sandstone cores

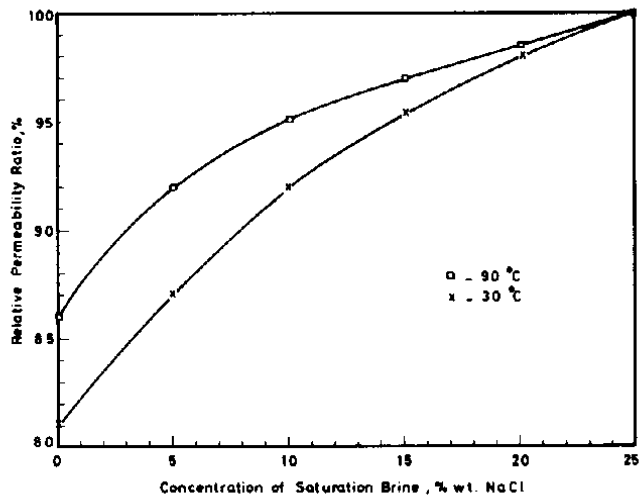

Fig. 7. Variation of relative permeability ratio with concentration at different temperatures and 1000 psig pressure, Alkhalji sandstone cores

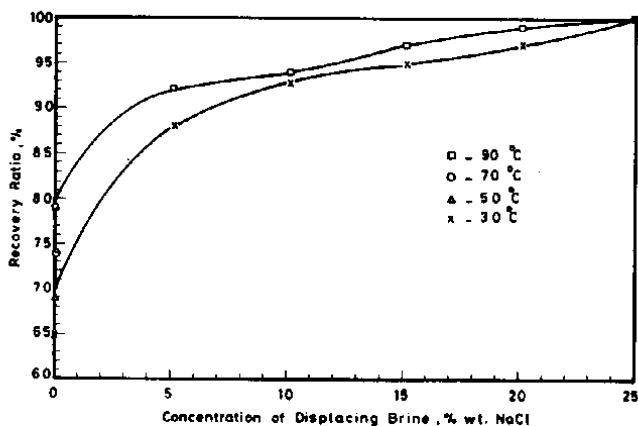

Fig. 8. Variation of recovery ratio with concentration at different temperatures and 1000 psig pressure, Aramco sandstone cores

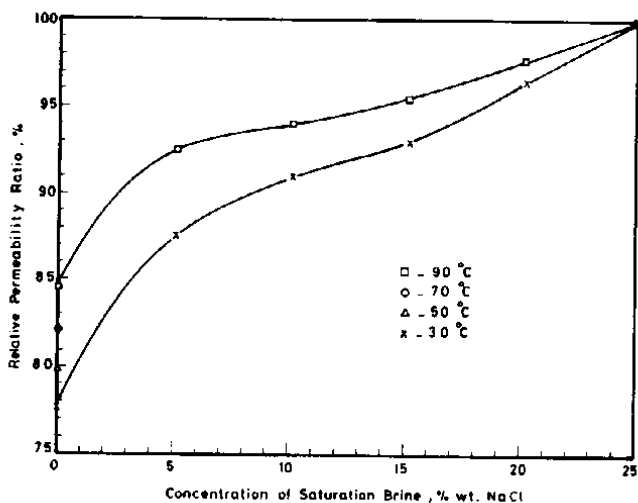

Fig. 9. Variation of relative permeability ratio with concentration at different temperatures and 1000 psig pressure, Aramco sandstone cores

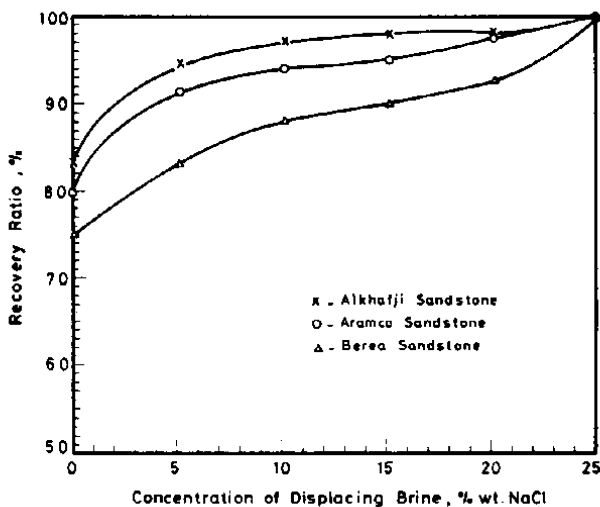

Fig. 10. Average variation of recovery ratio with concentration at 90°C

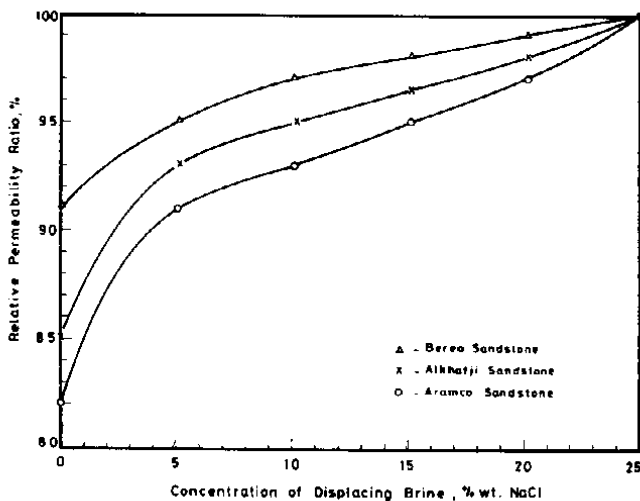

Fig. 11. Average variation of relative permeability ratio with concentration at 90°C

Temperature may have also reduced the effect of clay swelling and migration. Although increased temperature decreases water viscosity, thereby increasing the mobility of any ion in the water, it also lowers the weak bond of free ions within the clay. This will result in a decrease in the average residence time of the absorbed water molecules in the clay by decreasing the effective thickness of the absorbed water layer. Consequently the final volume to which the clay expands will be smaller resulting in a net decrease in formation damage.

### 5. Conclusion

The effect of water sensitivity on the permeability of three types of sandstone cores having different porosities, clay content and milliequivalents of exchangeable ions was studied at different temperatures and pressures. The following conclusions are derived within the framework of the experiments conducted by the experimental apparatus and the limitations imposed.

Increasing the temperature decreases the effect of damage on relative permeabilities and residual saturations as have been shown by monitoring changes in the % recovery and relative permeability ratio. Overburden pressure has no effect on this phenomenon.

### References

- [1] White, E.J.; Baptist, O.C. and Land, C.J. "Susceptibility of petroleum reservoir sands power to water damage power river basin, Wyoming." *35th Annual SPE of AIME Fall Meeting*, Denver, Colorado, Oct. 2-5 (1960), preprint No. SPE 1514-G.
- [2] Tignor, W.M. "Clay minerals and permeabilities of appalachian oil sands." *R.I. 5379 USBM*, (1957).
- [3] Lindlof, J.C. and Kenneth, G.S. "A case study of seawater injection incompatibility." *J.P.T.*, 35 (1983), 1256.
- [4] Koltz, J.A.; Kruger, R.F. and Pye, D.S. "Effect of formation damage on well productivity." *J.P.T.*, 26 (1974), 1303.
- [5] Baptist, O.C. and Sweeny, S.A. "Effect of clays on the permeability of reservoir sands to various saline waters wyoming." *R.I.* (1955), 5180, USBM.
- [6] Jones, F.O. "Influence of chemical composition on clay blocking permeability." *J.P.T.* 16 (1964), 441.
- [7] Omar, A.E.; El Gasler, M.M. and Dahab, A. "Effect of salinity on permeability, Riyadh, Saudi Arabia." *KACST Project No. AR-5-28*, (1987), 2nd Progress Report.
- [8] Gray, D.N. and Rex, R.W. "Formation damage in sandstones caused by clay dispersion and migration." *14th Nat. Con. on Clay and Clay Minerals*, 355, New York, (1966).
- [9] Mungan, N. "Permeability reduction through changes in pH and salinity." *JPT*, 17 (1965), 1449.
- [10] Gruesbeck, C. and Collins, R.E. "Entrainment and depositing of fine particles in porous media." *SPEJ*, 22 (1982), 847-856.
- [11] Sinnokrot, A.A. "The effect of temperature on capillary pressure curves of limestones and sandstones." *Ph.D. dissertation*, Stanford Univ, Standford, California, (1969).
- [12] Davidson, L.B. "The effect of temperature on the permeability ratio of different fluid pairs in two-phase systems." *JPT*, 21: (1969), 1037.
- [13] Ehrlich, R. "The effect of temperature on water-oil imbibition relative permeability, Texas." *SPE-AIME Dallas*, (1970), preprint No. SPE 3214 p.

- [14] Lo, H.Y. and Mungan, N. "Effect of temperature on water-oil relative permeability in oil-wet and water-wet systems." *48th Annual SPE of AIME Fall Meeting*, Las Vegas, Sept. 30 - Oct. 3, (1973), preprint No. SPE 4505 p.
- [15] Poston, S.W.; Ysrael, S.C.; Hossain, A.K.; Montgomery, E.F., and Ramey, H.J. "The effect of temperature on irreducible water saturation and relative permeability of unconsolidated sands." *SPEJ*, 10 (1970), 171.
- [16] Weinbrandt, R.M.; Ramey, H.J. and Casse, F.J. "The effect of temperature on relative and absolute permeability of sandstones." *SPEJ*, 15 (1975), 376
- [17] Fatt, I. "The effect of overburden pressure on relative permeability." *Trans. AIME*, 198 (1953), 325.
- [18] Fatt, I. "Pore volume compressibilities of sandstone reservoir rock." *JPT*, 3 (1958), 64.
- [19] Thomas, R.D. and Ward, G.C. "Effect of overburden pressure and water saturation on gas permeability of tight sandstone cores." *J.P.T.* 24 (1972), 121.
- [20] Johnson, E.F.; Bossler, D.P. and Naumann, V.O. "Calculation of relative permeability from displacement experiments." *Trans. AIME*, 216 (1959), 61.

(Manuscript Received: 23-6-1987; Accepted: 22-3-1988)

## Appendix I

### Calculation of Relative Permeabilities using Johnson-Boller-Naumann Method

This method depends on the equations formulated by Johnson *et al.* [20]. It requires the knowledge of the porosity and the pore volume (PV), both the viscosities of oil and water ( $\mu_o$  and  $\mu_w$ ), the initial water saturation  $S_{wi}$ , the number of pore volumes injected ( $N_{pv}$ ) at a given time interval  $t$ , and the water oil ratio in effluent (WOR). The fraction of displaced phase in the effluent ( $f_o$ ) would then be defined as:

$$f_o = \frac{d(S_{wav})}{dN_{pv}} \quad (1)$$

where,  $S_{wav}$  is the average water saturation.

If for a certain given reading of oil volume displaced  $V_o$  the total cumulative oil volume displaced was  $V_{oc}$  then water saturation ( $S_w$ ) would be defined by the following equation:

$$S_w = S_{wav} - f_o(N_{pv} - \frac{V}{2PV}) \quad (2)$$

where,  $V$  is the volume of effluent.

The oil saturation  $S_o$  would then be

$$S_o = 1 - S_w \quad (3)$$

If we define the relative injectivity ( $I_r$ ) as the ratio of the intake capacity to the initial intake capacity, then

$$I_r = \frac{(\Delta V / \Delta t \Delta p)}{(\Delta v_i / \Delta t_i \Delta p_i)} \quad (4)$$

Where the subscript  $i$  denotes initial conditions when oil alone was flowing through the system. Omitting the lengthy derivations of Johnson *et al.* we have

$$K_{ro} = \frac{f_o}{d (1/N_{pv} I_r / d (1/N_{pv}))} \quad (5)$$

and

$$k_{rw} = \frac{(1 - f_o)}{f_o} \frac{\mu_w}{\mu_o} k_{ro} \quad (6)$$

## دراسة على تلف الطبقة الحاملة للزيت تحت محاكاة ظروف المكمن

عدنان عيد عمر

قسم هندسة النفط، كلية الهندسة، جامعة الملك سعود، ص.ب. ٨٠٠،

الرياض ١١٤٢١، المملكة العربية السعودية

ملخص البحث: لقد اتضحت ظاهرة طبيعية من بين ظواهر تلف الطبقة الحاملة للزيت نتيجة للتباين بين أملاح مياه هذه الطبقة وأملاح المياه المحقونة في عمليات الغمر بالمياه ونتيجة لهذا التلف تقل نفاذية الصخور الرملية بصورة جلية مما يؤدي بدوره إلى انخفاض كمية العائد النفطي. إن التلف الناتج عن هذه الظاهرة كما تم إثباته معملياً يرجع إلى انتفاخ الطفلة أو إلى انتقالها داخل العينات الصخرية أو اليها معاً.

ولقد قيس الانخفاض في كمية العائد النفطي والنفاذية النسبية الذي سببه الانخفاض التدريجي في تركيز المحلول المزيح تحت درجات حرارة وضغوط مختلفة لثلاث عينات رملية ووجد أن تلف الطبقة يحدث عند جميع الضغوط ودرجات الحرارة التي أجريت عندها الاختبارات وأن الزيادة في درجة الحرارة قللت الانخفاض في العائد النفطي ونسبة النفاذية النسبية، ولقد وجد أن أقصى تغير في العائد انخفض من ٣٤٪ عند درجة حرارة المعمل إلى ٢١٪ عند درجة حرارة ٩٠° لعينات الصخر الرملي المستعملة، وأن الضغط المحتوى له تأثير ضئيل على تلف الطبقة الحاملة للزيت.